



# Owner's and Installer's Manual for Room Heating Units

*Applicable to Software Version 2.00-2.14*



**Models:  
2102, 2103, 2104,  
2105, & 2106**

## **For Customer Use**

*Please record your model and serial number below. This number is found on the identification label located on the lower portion of the heater's left side panel. Retain this information for future reference.*

**Model No.** \_\_\_\_\_

**Serial No.** \_\_\_\_\_

***"Manufactured in North America"***



# Personal Safety Instructions

## Safety Alert Symbols

Three safety alert symbols may be used to alert you to personal safety instructions. They are:

- **Electrical (1 & 4)**
- **Mechanical (2)**
- **Fire (3)**

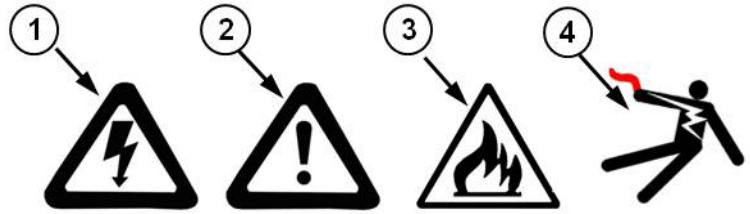

These safety alert symbols are used to alert you to hazards. Obey all safety messages that follow these symbols to avoid possible injury or death.

## Signal Words

Signal words that may appear next to the safety alert symbol are:

- **DANGER**
- **WARNING**
- **CAUTION**
- **IMPORTANT**
- **NOTE**

Carefully read and understand the instructions before you continue.

**DANGER** indicates a hazardous situation which, if not avoided, will result in death or serious injury.

**WARNING** indicates a hazardous situation which, if not avoided, could result in death or serious injury.

**CAUTION**, used with the safety alert symbol, indicates a hazardous situation which, if not avoided, could result in minor or moderate injury.

**IMPORTANT** indicates a special instruction or procedure which, if not followed, may cause damage to the equipment.

**NOTE** indicates additional information about a subject or procedure for a more efficient or convenient installation.

## Important

- The equipment described herein is intended for installation by a qualified technician in compliance with applicable local, state, and national codes and regulations.
- To insure proper installation and operation of this product, completely read all instructions prior to attempting to assemble, install, operate, maintain or repair this product. Upon unpacking of the system, inspect all parts for damage prior to installation and start-up.
- This manual should be retained by the owner upon completion of the installation and made available to service personnel as required.
- **Disclaimer:** In compiling this manual, Steffes has used its best judgement based upon information available, but disclaims any responsibility or liability for any errors or miscalculations contained herein, or any revisions hereof, or which result, in whole or in part, from the use of this manual or any revisions hereof.

# Safety Precautions

1. DO fully assemble the heater before energizing.
2. DO keep all explosive materials and/or flammable gases away from the room heating unit.
3. DO maintain the placement and clearance requirements.
4. DO keep items away from the discharge air grill area of the heater.
5. DO disconnect power to all circuits before servicing. This room heating unit may be connected to more than one branch circuit.
6. DO contact a qualified service technician for installation of and/or service to this heater to ensure it is installed and/or serviced in accordance with information contained herein and with national, state, and local codes and requirements.
7. DO contact a qualified service technician if a "CORE FAIL" message is displayed on the heater's control panel.



## WARNING

 **Hazardous Voltage: Risk of electric shock. Can cause injury or death. This heater may be connected to more than one branch circuit. Disconnect power to all circuits before installing or servicing. Installation of and/or service to this equipment MUST be performed by a qualified technician.**

 **Risk of fire. Can cause injury or death. Violation of the clearance requirements can cause improper operation of the equipment. Maintain the placement and clearance requirements specified.**

## Built-in Safety Devices

DEVICE NAME	FUNCTION	LOCATION ON HEATER
Core Charging High Limit Switch <i>(Manual Reset)</i>	These limits monitor temperature along the back and top panels of the heater and the brick core. If normal operating temperature is exceeded, one or both of these switches will interrupt power to the heating elements and the heater's control panel will display "CORE FAIL". If the "CORE FAIL" message occurs repeatedly, verify heater clearances have not been violated and that objects have not fallen between the heater and the wall. If clearances are correct, contact a service technician.	Inside the Back Panel <i>(Extends across the length of the heater)</i>
Clearance Violation High Limit Switch <i>(Manual Reset)</i>		Inside the Top Panel <i>(Extends across front edge)</i>
Discharge Air High Limit Switch <i>(Manual Reset)</i>	Monitors discharge air temperature and interrupts power to the control circuit if normal operating temperature is exceeded. This limit switch helps protect against the heating of objects which may obstruct the air discharge area or violate grill clearances. If normal operating temperature is exceeded, this switch will open. When this switch opens, the discharge air system is disabled and the heater's control panel display will no longer illuminate. To reset the system, press the manual reset button on the limit switch. If the switch opens repeatedly, verify that grill clearances are not violated. If correct, contact a service technician.	Inside the Air Discharge Compartment <i>(Grill Area)</i>
Tip Over Switch <i>(Heaters equipped with a security base only.) (Auto Reset)</i>	If the heater is not in the upright position, this switch interrupts power to the heating elements and the blower. This prevents the heater from storing heat in or discharging heat from the brick core.	Inside the Electrical Compartment <i>(Mounted on the Back Panel to the Left of the Relay Board)</i>
Power Indicator Light	The power indicator light indicates that power is being applied to the heater. Disconnect power to all circuits before installing and/or servicing this equipment.	Lower Right Corner <i>(2100 Series Plug-In Heaters Only)</i>



# Table of Contents

---

## Operation

General Operation .....	1.01
Control Panel.....	1.01
Room Temperature Control .....	1.02
Starting the System.....	1.02
Brick Core Charge Control .....	1.02
Automatic Charge Control .....	1.02
Manual Charge Control .....	1.02
Charge Control Override.....	1.03
Maintenance and Cleaning.....	1.03

## Installation

Shipping and Packaging.....	2.01
Placement .....	2.02
Clearance Requirements.....	2.02
Initial Set-Up .....	2.03
Securing the Heater .....	2.03
Wall Support Bracket.....	2.03
Security Base .....	2.03
Line Voltage Electrical Connections.....	2.04
Direct Wired Room Heating Units.....	2.04-2.05
Cord Connected (Plug-In) Room Heating Units .....	2.05
Low Voltage Electrical Connections - Peak Control .....	2.06
Power Line Carrier (PLC) Peak Control .....	2.06
Low Voltage Direct Wired Peak Control .....	2.07
Time Clock Module Peak Control .....	2.08
Line Voltage Peak Control .....	2.08
Low Voltage Electrical Connections - Outdoor Temperature Sensor (Optional).....	2.08
Brick Loading.....	2.09
Configuration Menu .....	2.10
Installer's Final Check-Out Procedure .....	2.11

## Appendix

Specifications.....	A.01
Parts Diagram .....	A.02
Parts List.....	A.03
Internal Line Voltage Wiring Diagrams.....	A.04
Manual Reset Limit Controls .....	A.05
Internal Low Voltage Wiring Diagram.....	A.05
Help Menu .....	A.06
Error Codes.....	A.06-A.07
Hinging the Right Side Panel .....	A.08
Glossary .....	A.09

## Warranty

# 1

## Operation

### GENERAL OPERATION

Steffes ETS room heating units utilize off-peak electricity available during those times of the day or night when the Power Company can supply electricity more economically. During off-peak hours, the room heating unit converts electricity to heat and stores the heat in its ceramic brick core. The heater stores heat at varying levels depending upon outdoor temperature, owner preference, utility peak conditions, and the requirements of the space being heated.

A small amount of heat is radiated through the heater's cabinet; however, most of the heating is accomplished by a thermostatically controlled blower. When the room temperature sensor senses a temperature below the room temperature set point, the blower circulates room air through the brick core. This air is heated and discharged back into the room to maintain a constant, comfortable room temperature.

### CONTROL PANEL

Operation of the heating system is automatic. Operational function settings are stored in a microprocessor on the processor control board. These settings are modified, if necessary, through the Configuration Menu as described on page 2.10. In most applications, **the system is configured upon installation** and no further changes are required.

The four digit LED displays specific operating information. In standard operation, these digits continuously display one of the following brick core operating modes followed by current room temperature.

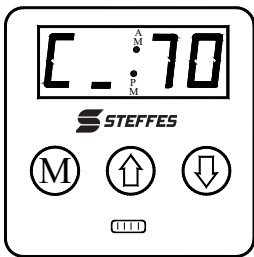

Control Panel  
Figure 1

C = Charge period or off-peak time.



P = Peak period or on-peak time.

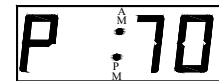

A = Anticipated peak period or pre-peak time.  
(Specialty Applications Only)

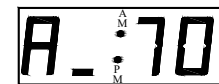

**A bar illuminates on the lower portion of the display's second digit whenever the heating elements are energized.**

### AM and PM Indicator Lights



The AM and PM indicator lights are only applicable if the optional Steffes Time Clock Module is installed. With this module installed, the system displays time in 12 hour format and the light corresponding to either AM or PM will flash. The system can be configured to display time in a 24 hour format (military time), in which case both the AM and PM lights will be illuminated.

### **(M) Mode (EDIT) Button**

Activates the editing menu for changing the operating information of the heater.

### **(↑) Up and (↓) Down Arrow Buttons**

Increase or decrease room temperature set point. Also used to scroll up or down when viewing or modifying the heater's operating functions.

### **Interface Port**

Allows technician external access for advanced operating modes, updating software, and troubleshooting.



## ROOM TEMPERATURE CONTROL

The room temperature set point is adjusted by pressing the up arrow to increase or the down arrow to decrease the set point. When the heater senses a heat call, the variable speed blower is energized and circulates room air through the brick core. This heated air is discharged into the room to maintain the desired temperature. In an effort to keep the room temperature constant, the blower automatically adjusts to the appropriate speed and may continue to operate after the set point has been reached.

If the owner prefers to monitor room temperature at a point away from the heater, an optional remote room temperature sensor is available. A remote room sensor also provides more even heat distribution in an area where more than one heater is installed. It is recommended to use the optional remote room sensor in applications where the right side panel has less than a 12" clearance or where the right side of the heater is exposed to abnormal temperature conditions such as drafts from a door or window.

## STARTING THE SYSTEM

On start-up, odors and/or small volumes of smoke relating to first time operation of the heating components may occur. There also may be an odor associated with dust accumulation if the heater is shut down for an extended period of time. Allow the heater to charge to its highest heat storage level (full core charge) to expel these odors. Refer also to maintenance and cleaning section of this manual.

Turning the heater "OFF" suspends all functions of the heater. To turn the heater "OFF", use the down arrow to decrease the room temperature set point until "OFF" is displayed on the faceplate. To turn the heater "ON", use the up arrow to adjust room temperature set point to the desired temperature.



**The heater MUST remain "ON" if being used to supply a peak control signal to other controlled loads.**

## BRICK CORE CHARGE CONTROL

The amount of heat stored in the heater's brick core can be regulated by automatic or manual charge control. The heater is factory preset for automatic charge control regulation. If manual charge control is desired, the heater must be reconfigured at the time of installation.

### ***AUTOMATIC CHARGE CONTROL***

With automatic charge control, the brick core charge level is regulated automatically in relation to outdoor temperature and the heating requirements. An optional outdoor sensor or Steffes power line carrier (PLC) system is required. The outdoor sensor or PLC system monitors outdoor temperature and provides this information to the heater. The heater responds by storing heat in the brick core accordingly. No user interface is required to adjust the brick core charge level.

### ***MANUAL CHARGE CONTROL***

If manual charge control is being used, the brick core charge level must be regulated by the user. During the heating season, the user needs to periodically adjust the brick core charge level setting in relation to outdoor temperature and the heating requirements of the area. To configure the heater for manual charge control, refer to the Configuration Menu (Page 2.10).

#### ***Adjusting the Brick Core Charge Level (Manual Charge Control)***

**Step 1** Press and release the **M** button until "CORE" is displayed.

**Step 2** Press the up or the down arrow button to adjust the brick core charge level set point. The charge level to be targeted can be set to any value from 0 to 100 percent.

**Step 3** Once the desired charge level is set, press the **M** button once to return to normal display mode.

## CHARGE CONTROL OVERRIDE

The heater is equipped with a charge control override feature that allows the user to force the heater to target a full core charge level. This override can be initiated or cancelled at any time. If an override is initiated, the heater targets a full core charge level during the next off-peak period. It continues to charge during off-peak hours until the heater achieves full (maximum) core charge or until the override is cancelled. Once full charge is achieved or the override is cancelled, the heater charges according to its standard configuration.

### *Initiate the Charge Control Override*

**Step 1** Press and hold the **M**, the up arrow, and the down arrow buttons at the same time.

**Step 2** The faceplate display will flash "FULL" and "ON". Continue to hold all three buttons until "ON" displays continuously on the faceplate.

**Step 3** Release the buttons. The override is now enabled. The faceplate will return to displaying its standard operating mode.

### *Cancel the Charge Control Override*

**Step 1** Press and hold the **M**, the up arrow, and the down arrow buttons at the same time.

**Step 2** The faceplate display will flash "FULL" and "OFF". Continue to hold all three buttons until "OFF" displays continuously on the faceplate.

**Step 3** Release the buttons. The override is now cancelled. The faceplate will return to displaying its standard operating mode.

## MAINTENANCE AND CLEANING

As with most heating systems, air borne particles and odors in the room may be drawn into the heating system and oxidized. Since the room air passes directly through the hot brick core of the ETS heater, the oxidation process will change the properties of these particles and odors. **Odors can be amplified; thus, it is recommended not to operate the heating system if odors such as those from paints, varnishes, or chemicals are present in the air.** Allow the area to be completely aired out before operating the heater.

As for air borne particles, after they have been oxidized they are expelled back into the room and may accumulate on the heater or other surfaces. Over time, these particles may appear as a black residue, commonly referred to as soot. High concentrations of air borne particles from such things as aerosols, dust, candles, incense, pet hair, high humidity, smoke, or cooking can contribute to poor indoor air quality and accelerate this process. To minimize the black residue build-up, clean the outer surface of the heater on a regular basis. Wash the cabinet, only when cool, with a nonabrasive household cleaner. Do not use scouring powders or furniture polish. Steffes recommends using "Soft Scrub with Bleach" brand cleanser or an equal.

Regularly vacuum around all sides of the heater. Check the back of the heater to make sure no objects have fallen behind it and the grill area to make sure there isn't anything obstructing air flow. Check all sides of the heater to be sure the required clearances are not being violated. Objects should never be placed on top of the heater.

No additional routine maintenance is required; however, having a professional service technician clean the blower periodically will decrease the likelihood of undesirable blower noise due to dust accumulation.



**No heater panel, with the exception of the painted front panel and painted right side panel, can ever be removed from the heater. Should any other exterior panel(s) be removed, the heater must be taken out of service permanently. All panels must be in place when operating the heater.**

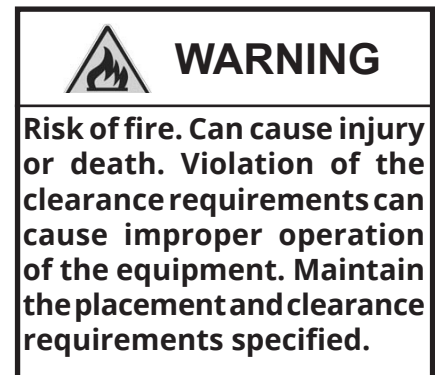

# 2 Installation

## SHIPPING AND PACKAGING

The heater should always be transported in an upright position to avoid damage to internal components and insulation materials. The items shipped with each heater include the following:

CAUTION

**Risk of personal injury. Steel edges can cut. Use caution when installing or servicing equipment.**

### ① BOXES OF CERAMIC BRICK



*(shipped separately and packaged 2 bricks per package)*

MODEL	BRICK
2102 plug-in	8 pkgs
2102	8 pkgs
2103	12 pkgs
2104	16 pkgs
2105	20 pkgs
2106	24 pkgs

### ② INFORMATION PACKAGE *(includes Owner's Manual, Warranty Registration Card, and Brick Installation Tool)*

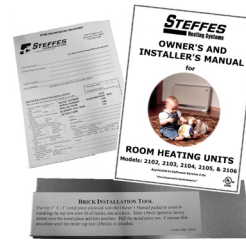

*(shipped inside the box on top of heater)*

### ③ WALL SUPPORT BRACKET

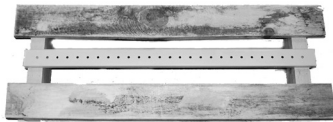

*(placed on shipping pallet under heater...used in all heaters except plug-in models)*

or

### SECURITY BASE

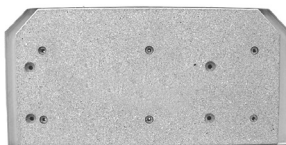

*(packaged in heater box on back side... used only in plug-in models)*

### ④ MOUNTING HARDWARE PACKAGE



*(shipped inside heater's electrical compartment...used in all heaters except plug-in models)*

or

### SECURITY BASE KIT



*(shipped inside heater's electrical compartment... used only in plug-in models)*



## PLACEMENT

The heater can be placed on an interior or an exterior wall. Ideal placement is along an interior wall, adjacent to an exterior wall. To find the best location for the heater, consider the following:

- **Physical Dimensions** - All clearance requirements specified in the Clearance Requirements section (Page 2.02) **MUST** be followed to ensure proper operation, safety, and performance of the equipment.
- **Weight** - The weight of the heater **MUST** be considered when selecting a location. If there are structural weight concerns, consult a building contractor or architect before installing.
- **Flooring** - The heater can generally be placed on any standard flooring. The bottom of the heater will be warm in normal operation; therefore, discoloration under the heater may occur to certain flooring products. Contact the flooring manufacturer or Steffes Corporation with questions regarding the acceptability of the floor covering. If installing on extremely thick carpet, it may be necessary to slightly elevate the heater as carpet should remain at least  $\frac{3}{4}$  inch away from air discharge grill openings.
- **Room Temperature Sensing** - To ensure accurate room temperature sensing, avoid installing the heater near an open stairwell, near sources of heat or cold, or with less than 12" clearance on the right side. Refer to Room Temperature Control section (Page 1.02) for information regarding the optional remote room temperature sensor.



**Special requirements must be considered if placing the system in a garage or other area where combustible vapors may be present. Consult local, state, and national codes and regulations to ensure proper installation.**

## CLEARANCE REQUIREMENTS

There are minimum clearances that must be maintained when choosing a location. (See Figure 2.) These areas surrounding the heater must be kept open and free of debris. Objects such as curtains, furniture, or bed covers must be kept a minimum of 4" from all surfaces of the heater. The back clearance is provided by the wall mounting bracket or by the security base. **DO NOT** place objects of any kind on top of the heater. The heater may be recessed into a wall; however, access to the heater's front panel and grill **MUST NOT** be obstructed or enclosed and all clearance requirements **MUST** be maintained.

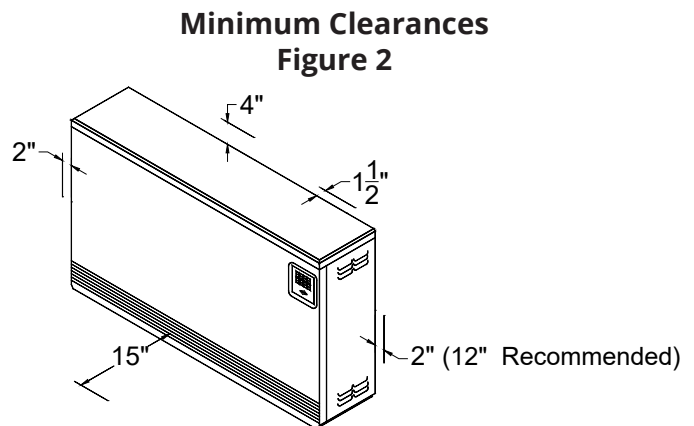

### Minimum Clearances

Top	4"
Front & Grill	15"
Sides	2"
Back	1 1/2"



## WARNING

**Risk of fire. Can cause injury or death. Violation of the clearance requirements can cause improper operation of the equipment. Maintain the placement and clearance requirements specified.**



**A clearance of 12" is recommended on the right side of heater. If there is less than a 12" clearance, a remote room temperature sensor is recommended to ensure accurate room temperature sensing. The 12" clearance also allows space for hinging the right side panel open for servicing.**

## INITIAL SET-UP

- Step 1** Unbox the heater and lift it off the shipping pallet. Place the shipping box aside until the brick loading process (Page 2.09).
- Step 2** Place the heater in the desired location and check for proper clearances on all sides.
- Step 3** Remove the screws at the lower edge of the painted front panel.
- Step 4** Pull the lower edge of the panel forward and unhook it from the top panel. Carefully place the painted front panel aside to avoid damage.



**No heater panel, with the exception of the painted front panel and painted right side panel, can ever be removed from the heater. Should any other exterior panel(s) be removed, the heater must be taken out of service permanently. All panels must be in place when operating the heater.**

## SECURING THE HEATER



### WARNING

**Risk of fire. Can cause injury or death. Failure to secure the heater can cause the heater to fall over. Properly secure the heater by using the wall support bracket to mount it to the wall or by installing the security base.**

The 2100 series room heating unit **MUST** be secured for safety purposes. A direct wired heater is secured with a wall support bracket, while a plug-in heater is secured with a security base.

### WALL SUPPORT BRACKET

- Step 1** Remove the mounting hardware package from its shipping position inside the electrical compartment.
- Step 2** Place the top of the wall support bracket 23 1/2" from the floor and secure it to the wall with the lag bolts provided. The bracket **MUST** be mounted so the lag bolts secure into wood wall studs. If the wall is not a standard wood studded structure, alternate fasteners must be used.
- Step 3** Attach the wall support clips to the back of the heater.
- Step 4** Set the carriage bolts aside as they will be used to attach the heater to the wall support bracket after the field wiring connections are made.

**Wall Support Bracket Mounting  
Figure 3**

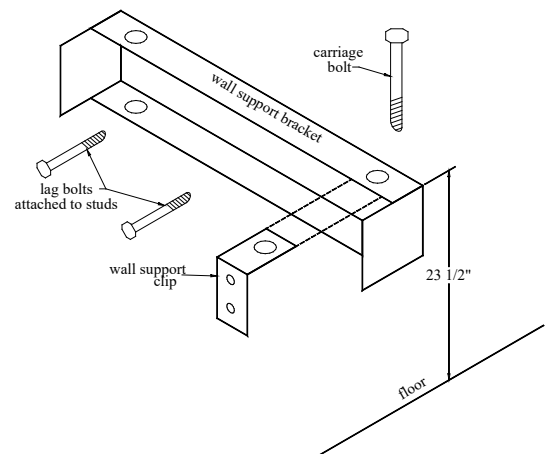

### SECURITY BASE

120V plug-in cord models come equipped with a security base. This base must be attached to the bottom panel of the room heating unit. It is packaged inside the shipping box on the back side of the heater.

- Step 1** Remove the security base mounting hardware package from its shipping position inside the electrical compartment.
- Step 2** Gently lay the heater on its back. For ease of installation, slightly elevate the bottom of the heater.
- Step 3** Align the holes in the security base with the pre-drilled holes in the bottom of the heater. Using the six #14 x 1 1/4" sheet metal screws and washers provided in the mounting hardware package, attach the security base to the painted bottom panel.



**The angled corners of the security base will be towards the front of the heater and the painted side of the security base faces up.**

- Step 4** After the base is attached, return the heater to its upright position and place in desired location. **DO NOT** energize the heater until installation is complete.

## LINE VOLTAGE ELECTRICAL CONNECTIONS

Steffes room heating units are available for connection to various input voltages. Standard configuration for direct wired heaters is 240V; cord-connected heaters are configured to plug into a 120V wall outlet. To determine the configuration of the heater, refer to the Unit Identification Label on the lower left side panel. (See Figure 4.) All heaters are UL and cUL safety listed.

Sample Unit Identification Label  
Figure 4



**STEFFES**  
Manufactured in North America

Electric Air Heater  
Patent Number: 5.042.081



3P23

	VAC	Watts	Hz
Charge Crct #1	240/208	3600/2700	60
Charge Crct #2	240/208	3600/2700	60
Fan/Cntrl Crct	240/208	120	60

Use copper supply wire rated for 75 degrees C minimum.

**Required Clearances:** Allow a minimum of 2 inches sides, 1.5 inches back, 4 inches top, and 15 inches front. DO NOT enclose or obstruct access to the heater's front panel and grill.

**WARNING:** Failure to maintain the required clearances listed above may cause a risk of fire.

### WARNING

**HAZARDOUS VOLTAGE:**  
Risk of electric shock. Can cause injury or death. DO NOT energize the heater until installation is complete. Equipment must be installed by a qualified technician in accordance with applicable local, state, and national codes and regulations.

### DIRECT WIRED ROOM HEATING UNITS

In standard configuration, the charging circuit of the heater is wired for connection to 240V/208V. If connecting to 208V, the heater will operate at 75% of its rated wattage. The blower and controls circuit in the heater is configured for 240V. If the control circuit is to be connected to 120V or 208V, contact the factory.



#### 208V SYSTEMS ONLY:

In standard configuration, Steffes heaters are dual rated for 240V and 208V power connections. The heaters are factory configured for 240V. If the control circuit is operating on 208V power, the value in Location 16 (L016) must be changed to 210 and the value in Location 28 (L028) must be changed to a value of 5 for heaters equipped with Fasco blower and 10 for P-Tech blower.

### Field Connection Wire and Circuit Breaker Sizing Guide

All 2100 series heaters are equipped with a two-circuit element feed option and a fan/control circuit (Figure 5 on page 2.05). Refer to the Unit Identification Label for proper sizing of each circuit. If single-feed connection is used, size the circuit for total wattage. (Charge Crct #1 + Charge Crct #2 + Fan/Cntrl Crct = Total Wattage.)

Wire Size	Maximum kW			Maximum Circuit Breaker Size
	240 VAC	277 VAC	208 VAC	
#14 AWG	2.8	3.3	2.4	15
#12 AWG	3.8	4.4	3.3	20
#10 AWG	5.7	6.6	4.9	30
#8 AWG	7.6	8.8	6.6	40
#6 AWG	11.5	13.2	9.9	60

Use copper wire rated at 75° C minimum only.



**This field connection wire and breaker size guide reflects only the code interpretation of Steffes. It is the responsibility of the installer to comply with all applicable codes and regulations.**

## Field Wiring

**Step 1** After establishing placement of the heater, mount a field connection junction box in a location where heater-to-field wiring connections can be made easily. The junction box can be located beside the heater, behind the heater, or mounted in the floor below the heater. Steffes recommends a steel junction box to provide protection against overheating.



**The junction box MUST remain accessible for future service to the heater and MUST be sized in accordance with all applicable electrical codes and regulations.**



## WARNING

**Risk of injury or fire. Poor or marginal electrical connections will cause the connection to overheat and fail. Use extreme caution when making all electrical connections.**

- Step 2** Route the proper size and type of wiring from the breaker panel to the field connection junction box.
- Step 3** Connect the field wiring to the wiring harness (umbilical cord) of the heater inside the junction box.
- Step 4** Remove the orange breaker panel label from the mounting hardware package. This label **MUST** be applied in the electrical service (breaker) panel and marked accordingly to identify the branch circuits feeding the room heating unit.

**Typical System Wiring Diagram  
Figure 5**

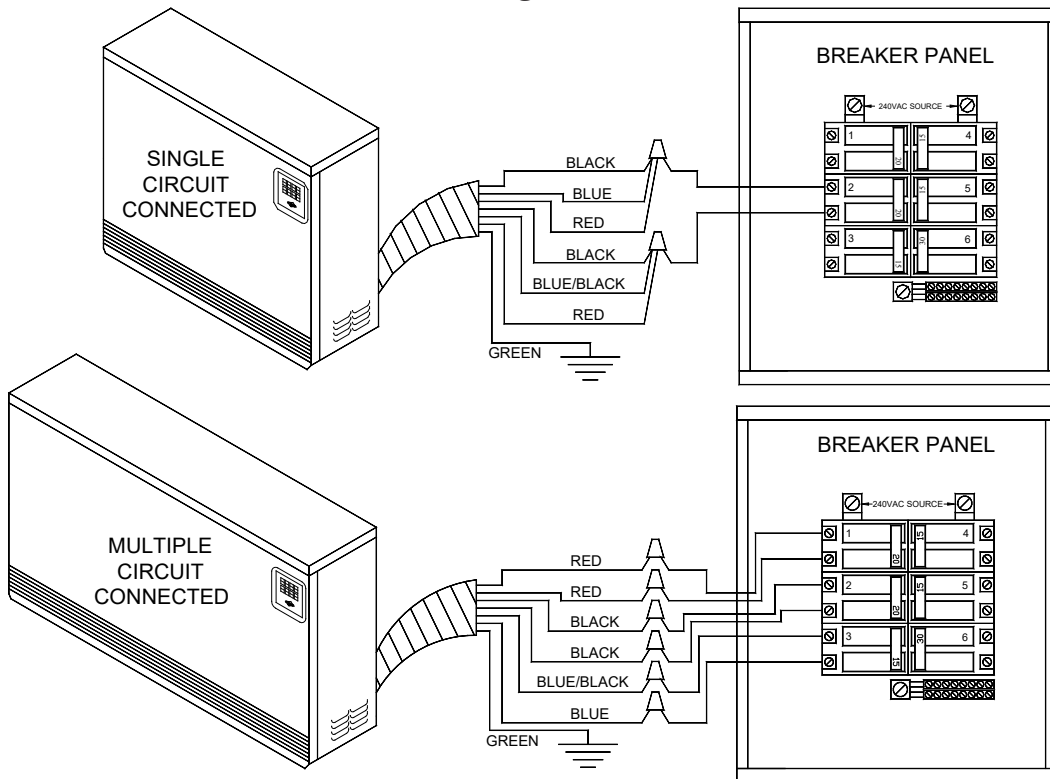

**Wiring Harness (Umbilical Cord) Color Code Chart**

WIRE COLOR	CIRCUIT DESCRIPTION
Black	Circuit feed for two of the four heating elements
Red	Circuit feed for two of the four heating elements
Blue and Blue/Black	Circuit feed for the blower and heater's control
Green	Ground



**Connections shown are for systems with a 240V/208V blower/control circuit. Refer to the Unit Identification Label on the lower left side panel of the heater for proper voltage configuration.**

## CORD-CONNECTED (PLUG-IN) ROOM HEATING UNITS

All cord-connected heaters are factory-configured to be plugged into a 120V wall outlet. The circuit outlet the heater is plugged into should be designated solely to the heater for circuit sizing purposes as well as peak control and metering purposes in some instances. To determine the correct circuit size, refer to the Field Connection Wire and Circuit Breaker Sizing Guide in this manual.

120V cord-connected room heating units must only be used with receptacles that are of the grounding type and suitable for the load of the heater. (See Figure 6 for cord and receptacle requirements.)

### 120V Receptable Requirements

Figure 6

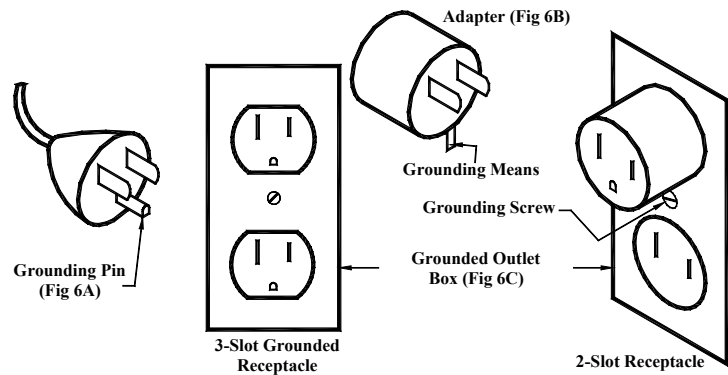

The room heater's cord has a plug as shown in Figure 6A. An adapter, as shown in Figure 6B, is available for connecting three-blade grounding type plugs to two-slot receptacles. The green grounding means extending from the adaptor must be connected to a permanent ground, such as a properly grounded outlet box as shown in Figure 6C. This adaptor should not be used if a three-slot grounded receptacle is available.

## PEAK CONTROL

Steffes ETS heating equipment is generally controlled by the Power Company via a peak control signal. This signal can be sent to the heater using the Steffes Power Line Carrier system, low voltage wiring, a Steffes Time Clock Module, or line voltage wiring. In applications utilizing automatic charge control, outdoor temperature information is required and can be received via an outdoor sensor or power line carrier control.

**NOTE** **IMPORTANT**

**Never install any wiring in the line voltage compartment of the 2100 series heater unless it is rated for line voltage.**

The 2100 series room heating unit is factory configured for use with power line carrier control. Refer to the Configuration Menu (Page 2.10) for information on configuring the heater for the application.

## POWER LINE CARRIER (PLC) PEAK CONTROL

The optional Steffes Power Line Carrier (PLC) control system has the ability to communicate with the heater through the existing electrical circuits in the structure. With the power line carrier option, hard wired low voltage connections from the power company's peak signaling switch connect directly to the transmitting device. The switch signals peak control times to the transmitter, the transmitter sends the signal to an unlimited number of 2100 series heaters, which receive this information and respond accordingly.

In addition to providing peak control signals, the transmitting device also provides outdoor temperature information, room temperature set back, and anticipated peak utility control signals (if applicable).

As the PLC system is optional, it must be specified at the time of ordering. If utilizing a PLC system, refer to the Owner's and Installer's manual accompanying the transmitting device for information on the installation and operation of the power line carrier control system.



**PLC Communication is very reliable in most applications but can be affected and hindered by connection method used, electrical layout of the application, operation of other equipment in the same electric system, dirty power, etc. Steffes does not guarantee effective communication of the PLC system in all applications and is not responsible for any communication issues outside normal operating malfunctions.**

## LOW VOLTAGE DIRECT WIRED PEAK CONTROL

If using the low voltage control option, the heater is direct wired to the power company's peak control switch. Field connections from the switch are made to the heater's low voltage wiring harness through the low voltage raceway. These wires are also accessible from inside the electrical compartment. Class II (low voltage) wiring should never enter a line voltage area of the heater, including its umbilical cord.



## IMPORTANT

If routing low voltage wire near line voltage conductors, shielded wiring must be used.

Some power companies also use anticipated (pre-peak) signals. If applicable to your installation, the control switch providing the pre-peak signal can also be connected directly to the heater with low voltage wire. Refer to the Low Voltage Connections Direct Wired Controls Diagram (Figure 7) for reference to peak and anticipated peak low voltage connections.

**Single Unit - Low Voltage Connections Direct Wired Controls**  
Figure 7

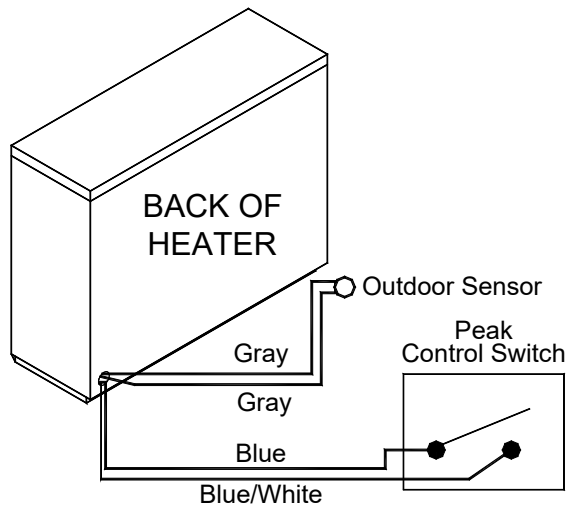

**Multiple Unit - Low Voltage Connections Direct Wired Controls**  
Figure 8

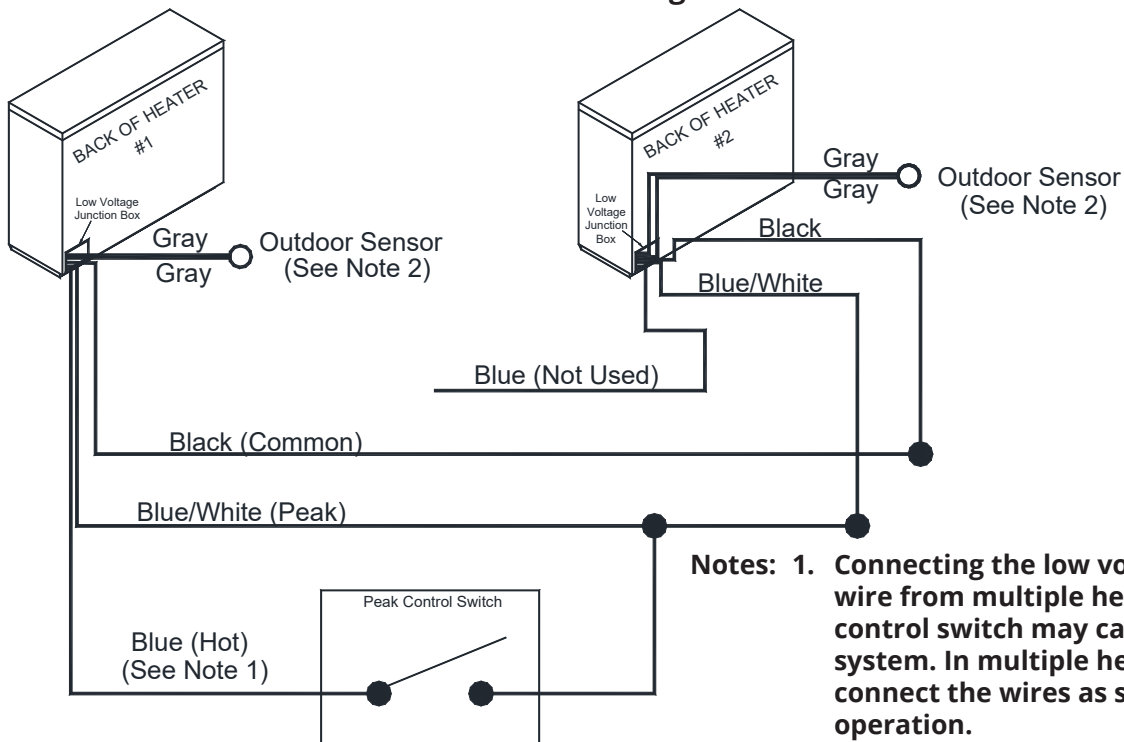

- Notes:**
1. Connecting the low voltage hot (blue) wire from multiple heaters to a single control switch may cause damage to the system. In multiple heater applications, connect the wires as shown for proper operation.
  2. In this configuration, one outdoor sensor is needed for each heater installed.

### **TIME CLOCK MODULE PEAK CONTROL**

The Steffes time clock module (Order Item #1301014) is another option for providing a peak control signal to the heaters. The optional time clock module is installed inside the heater's line voltage electrical compartment and interfaces with the heater's relay board. Peak control times are required to be programmed into the heater once the module is installed to enable the time clock feature.

In addition to providing peak control signals, the time clock module can also provide automatic room temperature set back, if desired. Refer to the instructions provided with the time clock module for more information on the installation and operation of this device.

### **LINE VOLTAGE PEAK CONTROL**

Line voltage control is a method that employs the use of an external switching device to disconnect line voltage to the charging circuits during the peak times. If line voltage control is used, the blower/control circuit of the heater must be powered with a separate, uninterrupted, circuit. The display on the heater will continuously display an operating mode of "C" (charge) regardless of whether it is an off-peak or on-peak time.

## **LOW VOLTAGE ELECTRICAL CONNECTIONS - OUTDOOR TEMPERATURE SENSOR (OPTIONAL)**

The outdoor temperature sensor can be installed in one of two ways: direct wired to the system or wired to the Steffes power line carrier system. If direct wired to the heater, one sensor per heater is required. Refer to the Low Voltage Connection Diagrams (Figures 7 and 8) and the instructions included with the sensor for information on the installation of this device.

**Installation Methods:** A) Hard wired to the heater

**OR**

B) Connected to Power Line Carrier (PLC) - reference Owner's and Installer's Manual for this installation.

**Theory of Operation:** The outdoor sensor monitors outdoor temperature and provides this information to the system. The system responds by automatically storing heat in its brick core according to outdoor temperature and the heating requirements.

**Location of:** The outdoor sensor must be placed in a location where it can accurately sense outdoor temperature and is not affected by direct sunlight or other abnormal temperature conditions.

### **Wiring to heater:**

- Route low voltage wire from the outdoor sensor to the electrical compartment through one of the low voltage wire knockouts.
- Connect to the two gray wires in the low voltage raceway.
- If the sensor wiring is routed through an external wall, the opening through which the wire is routed **MUST** be sealed. Failure to do so may affect the accuracy of the outdoor temperature sensor.
- The outdoor sensor can be extended up to a total of 250 ft if needed.
- Unshielded Class II (thermostat) wire can be used as extension wire as long as it is segregated from any line voltage cabling.
- No other loads can be controlled or supplied through this cable. It is for connection of the outdoor sensor **ONLY**.
- This low voltage cable **MUST** not enter any line voltage enclosure.

## **IMPORTANT**

**Unless servicing, power to the heater should not be turned off at the circuit breaker when using the Steffes Time Clock Module. If power is off to the blower/control circuit for an extended period of time, it may be necessary to reset the current day and time.**

## **IMPORTANT**

**If connecting to the Steffes power line carrier (PLC) system, follow the installation instructions in the PLC system's Owner's and Installer's Guide.**

## BRICK LOADING

**Step 1** Verify that the heater is not energized.

**Step 2 Direct Wired Room Heating Units Only** - Place the heater against the wall support bracket and use the carriage bolts provided to securely mount the heater to the wall.

**Step 3** Place the shipping box in front of the heater before loading the brick to catch brick debris, to protect the flooring, and for easy clean-up upon completion of the installation.

**Step 4** Remove the screws on the right side of the galvanized front panel and rotate the panel to the left to remove.

**Step 5** If installing a Model 2104, 2105, or 2106, remove and discard the cardboard spacer(s) from the brick core.

**Step 6** Begin brick loading with row one by installing the first brick face-up and sliding to the far right side of the heater's storage cavity. Be sure the grooved side of the brick is up and fits tight against the right air channel and the back insulation panel. Continue loading the bricks for Row 1 as shown in Figure 9. The insulation on the left side may need to be compressed to install the last brick on each row.



**To compress the side, squeeze the inner panel towards the outer panel as shown in Figure 9 below.**

**Step 7** Continue the brick loading process one row at a time. All bricks in rows one through seven must be loaded with the grooved side up. (See Figure 10.)

**Step 8** Install the eighth (top) row of bricks with the grooved side of the bricks facing down. (See Figure 10.) A 3" x 11" metal brick installation tool is enclosed in the information package to assist with loading the top row of brick. Lay the metal tool over the far right brick in row 7. Slide a brick over the metal piece and into position. Pull the metal piece out. Continue this procedure until the entire top row of brick is installed.

**Step 9** Once all bricks are loaded, replace the galvanized front panel.

## IMPORTANT

- ♦ The heater **MUST** be securely mounted to the wall or to its security base prior to brick loading.
- ♦ To properly seal the brick core, make sure all bricks are installed correctly.
- ♦ Install bricks carefully to avoid damage to the bottom and back insulation panels of the storage cavity.
- ♦ Maintain an even horizontal line across the brick core during brick installation so air flow through the heater is not obstructed.

**Brick Placement  
Figure 9**

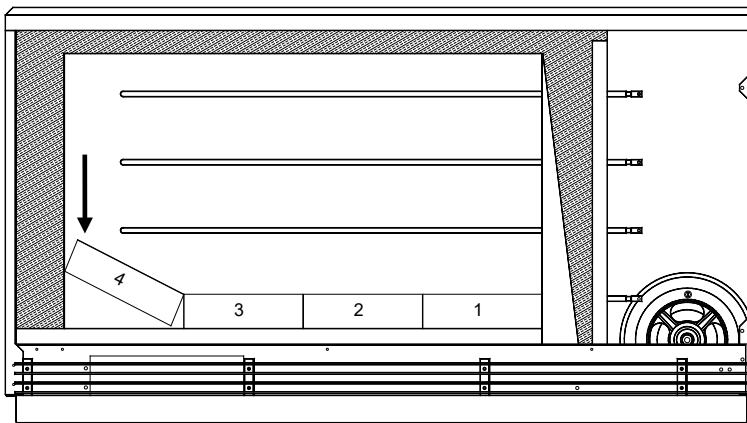

**Brick Loading  
Figure 10**

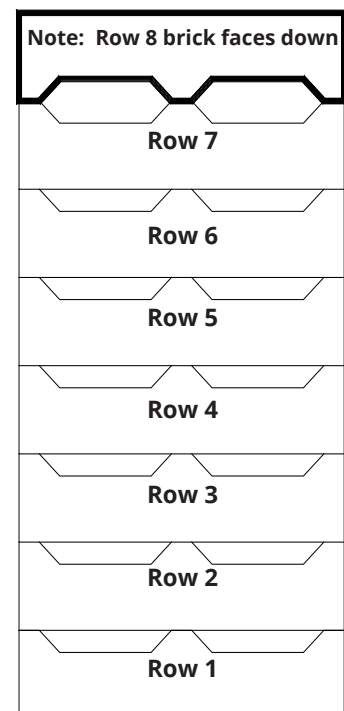



# CONFIGURATION MENU

Steffes 2100 Series room heating units have a Configuration Menu which allows them to be customized to the power company and consumer's needs. This menu can be accessed on start-up and allows configuration settings to be adjusted.

**IMPORTANT**

**If access to Configuration Menu times out, the system must be powered off at the circuit breaker and back on to re-enter the menu.**

## Accessing the Configuration Menu

- Step 1** Energize heater. Access to Configuration Menu is allowed for first two (2) minutes of operation. If heater has been energized for over two (2) minutes, it must be powered off and back on again.
- Step 2** Press and release the **M** button until the faceplate displays "CONF".
- Step 3** Press the up arrow once and the faceplate will display "C000". The display will flash between "C000" and the corresponding configuration value.
- Step 4** If necessary, edit the configuration by pressing and holding the **M** button while using the up or the down arrow button to change the value.
- Step 5** Once the value is correct, release the buttons and press the up arrow button to go to the next configuration (C001, C002, etc.).
- Step 6** Repeat steps 4 through 5 until all configuration settings have been adjusted to the desired values.
- Step 7** Once configured, use the down arrow to leave the Configuration Menu.  
In most applications only a few, if any, configuration changes will be necessary. Following is a description of the configuration settings and their functions:

## 2100 Series

Configuration Number	Method of Peak Control								
	Power Line Carrier (PLC) Peak Control *	Low Voltage Direct Wired Peak Control				Time Clock Module Peak Control		Line Voltage Peak Control	
		Peak Switch Closed for Charging		Peak Switch Open for Charging					
		Outdoor Sensor	No Outdoor Sensor	Outdoor Sensor	No Outdoor Sensor	Outdoor Sensor	No Outdoor Sensor	Outdoor Sensor	No Outdoor Sensor
C000	5	5	6	5	6	5	6	5	6
C001	60°F	60°F				60°F		60°F	
C002	20°F	20°F				20°F		20°F	
C003	Match to the Channel Selected at PLC	0				0		0	
C004	154	155	154	155	154	159	158	155	154
C005	0	1		0		0		0	
C006	6	6				6		6	
C007	30	30				30		30	
C008	5°F	5°F				5°F		5°F	
C009	5°F	5°F				5°F		5°F	
C010	90°F	90°F				90°F		90°F	
C011	70°F	70°F				70°F		70°F	
C012	60°F	60°F				60°F		60°F	
C013 - C021	N/A	N/A				Refer to the Time Clock Installation Instructions		N/A	

\*Factory Default is Power Line Carrier (PLC) Peak Control using Channel 3

## INSTALLER'S FINAL CHECK-OUT PROCEDURE

With the heater de-energized, hinge the right side panel open (Page A.08). Complete the system check-out below:

**Step 1** Inspect all field connections to ensure they are tight and that all wires are routed correctly.



**Class II (low voltage) wiring or any wiring not rated for line voltage should never be installed in a line voltage area.**

**Step 2** Check the damper system to ensure the damper operates freely and that there is no debris in this area, which could inhibit its operation. To do so, slowly press the damper lever extending from the damper downward. Be careful not to bend the damper actuator. If the damper is not free, remove the blower and clean any debris from the damper.

**Step 3** Make sure the blower operates by adjusting room temperature set point above the actual room temperature.

**Step 4** With the system in an off-peak (charge) mode, initiate the charge control override (Page 1.03).

**Step 5** Check for proper amperage draw on the charging circuit(s). Use the Charge Circuit Amperage Draw Chart for reference to the correct amperage of the specific heater being installed.

**Step 6** Verify that the heater receives and responds to the utility peak control device and that all other system controls are operating properly.

**Step 7** Place grill slats in position, if removed. Grill slats should bow up to direct airflow up, away from the floor.

**Step 8** Place the right side panel back into position and secure.

**Step 9** Return the control circuit board to its original position and install the painted front panel.

**Step 10** Verify that configuration settings are correct for the application. Refer to the Configuration Menu (Page 2.10).



**On start-up, odors and/or small volumes of smoke relating to first time operation of the heating components may occur.**

**Step 11** Make certain all fuses and/or circuit breakers are labeled in the distribution service panel as this system may be connected to more than one branch circuit.

**Step 12** Present owner with the manual and warranty information. **The owner's registration card must be completed and returned to Steffes Corporation to ensure warranty coverage.** The owner should retain the top portion of the card for their records.



### WARNING



**Risk of fire. Can cause injury or death. ETS devices run for long periods of time at high electrical loads. Poor or marginal connections will cause the connections to overheat and fail.**



**Risk of electric shock. Can cause injury or death. This heater may be connected to more than one branch circuit. Disconnect power to all circuits before installing or servicing. DO NOT remove the painted front panel while energized. Equipment must be serviced by a qualified technician.**

### CHARGE CIRCUIT AMPERAGE DRAW CHART

Input Wattage	Voltage	AMP Draw
1.32 kW	120	11.00
2.4 kW	240	10.00
3.0 kW	240	12.50
3.6 kW	240	15.00
4.5 kW	240	18.75
4.8 kW	240	20.00
5.4 kW	240	22.50
6.0 kW	240	25.00
7.2 kW	240	30.00
7.5 kW	240	31.25
9.0 kW	240	37.50
10.8 kW	240	45.00

*(AMP draw is calculated by taking the total input wattage divided by the input voltage. Allow +/- 5% tolerance at nominal input voltage.)*



# Appendix

## SPECIFICATIONS

Model	2102 plug-in	2102	2103	2104	2105	2106
Length - inches	30	30	37	44	51	58
Height - inches	24.5	24.5	24.5	24.5	24.5	24.5
Depth - inches (w/out wall bracket) (w/wall bracket)	10.5 12	10.5 12	10.5 12	10.5 12	10.5 12	10.5 12
Number of Bricks	16	16	24	32	40	48
Number of Brick Pkgs.	8	8	12	16	20	24
Weight of Heater - lbs	105	91	112	126	145	164
Weight of Bricks - lbs	176	176	264	352	440	528
Installed Weight - lbs	281	267	376	478	585	692
*Element Voltage	120	240 (std) 208 & 277 opt	240 (std) 208 & 277 opt	240 (std) 208 & 277 opt	240 (std) 208 & 277 opt	240 (std) 208 & 277 opt
*Inputs Available - kW	1.32	2.4, 3.0, 3.6	3.6, 4.5, 5.4	4.8, 6.0, 7.2	6.0, 7.5, 9.0	7.2, 9.0, 10.8
*Blower/Control Voltage	115	230 (std) 120 or 208 opt	230 (std) 120 or 208 opt	230 (std) 120 or 208 opt	230 (std) 120 or 208 opt	230 (std) 120 or 208 opt
Blower Wattage Minimum Maximum	30 120	30 120	30 120	30 120	30 120	30 120
Storage Capacity kWh BTU	13.5 46,062	13.5 46,062	20.25 69,093	27 92,124	33.75 115,155	40 136,480

*\* Refer to the Unit Identification Label on lower left side panel for data specific to your heater. In standard configuration, the heater can be connected to 208V or 240V. Rated input at 208V is 75% of rated 240V input. If full rated input is required in 208V applications, contact the factory.*

# PARTS DIAGRAM

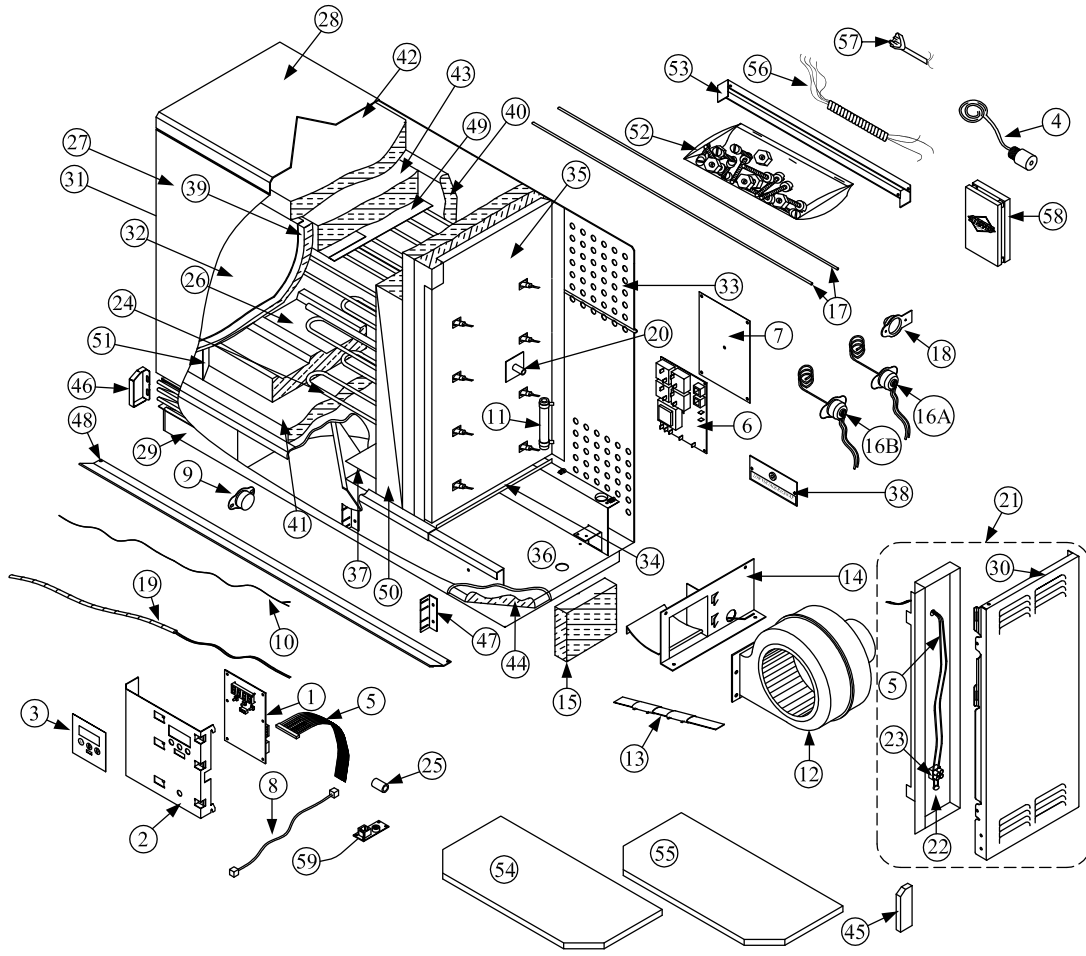

1. When ordering replacement parts, please include model number and serial number of the heater.
2. The blower resistor (Item #11) will vary depending on the blower (Item #12) installed in the heater. Reference the Parts List for more details.

## PARTS LIST

Ref No.	Description	2102 Plug-in Item #	2102 Item #	2103 Item #	2104 Item #	2105 Item #	2106 Item #
1.	Processor Control Board	1023065R	1023065R	1023065R	1023065R	1023065R	1023065R
2.	Processor Control Board Mounting Bracket	5943412	5943412	5943412	5943412	5943412	5943412
3.	Faceplate Label	1159029	1159029	1159029	1159029	1159029	1159029
4.	Outdoor Temperature Sensor (optional)	1302033	1302033	1302033	1302033	1302033	1302033
5.	Wiring Harness, Low Voltage	1011647	1011647	1011647	1011647	1011647	1011647
6.	Base I/O Relay Board	1023078R	1023078R	1023078R	1023078R	1023078R	1023078R
7.	Line Voltage Base I/O Barrier	1159060	1159060	1159060	1159060	1159060	1159060
8.	Interface Cable, 18"	1010014R	1010014R	1010014R	1010014R	1010014R	1010014R
9.	**Discharge Air High Limit Switch (285 Degree) Auto	1012018R	1012018R	1012018R	1012018R	1012018R	1012018R
"	**Discharge Air High Limit Switch (285 Degree) Manual	1012080R	1012080R	1012080R	1012080R	1012080R	1012080R
10.	Output Sensor (Thermocouple)	1040822	1040822	1040826	1040832	1040826	1040832
11.	***Blower Resistor (P-TECH)	1017047	1017049	1017049	1017049	1017049	1017049
"	***Blower Resistor (FASCO)	1017011	1017050	1017050	1017050	1017050	1017050
12.	***Blower Assembly (P-TECH)	1021036R	1021035R	1021035R	1021035R	1021035R	1021035R
	***Blower Assembly (FASCO)	1021030R	1021032R	1021032R	1021032R	1021032R	1021032R
13.	Damper Actuator Assembly	1043107R	1043106R	1043106R	1043106R	1043106R	1043106R

# PARTS LIST CONTINUED

Ref No.	Description	2102 Plug-in Item #	2102 Item #	2103 Item #	2104 Item #	2105 Item #	2106 Item #
14.	Damper Assembly	N/A	N/A	N/A	N/A	N/A	N/A
15.	Damper Assembly Insulation	N/A	N/A	N/A	N/A	N/A	N/A
16A.	**Core Changing Limit Switch Auto (Back Panel)	1040816R	1040816R	1040816R	1040817R	1040817R	1040818R
16A.	**Core Changing Limit Switch Manual (Back Panel)	1012088R	1012088R	1012088R	1012088R	1012090R	1012090R
16B.	Clearance Violation Limit Switch Manual (Top Panel)	1012091R	1012091R	1012091R	1012091R	1012092R	1012092R
17.	Core Changing High Limit Guide Tube (cut to size)	1105003	1105003	1105003	1105003	1105003	1105003
18.	Core Changing High Limit Bracket	5940190	5940190	5940190	5940190	5940190	5940190
19.	Brick Core Sensor (Thermocouple)	1043102R	1043102R	1043103R	1043103R	1043104R	1043104R
20.	Brick Core Sensor Tube	5943222	5943222	5943220	5943220	5943220	5943220
21.	Room Temperature Sensor Mounting Panel	1040860	1040860	1040860	1040860	1040860	1040860
22.	Room Temperature Sensor	1013034	1013034	1013034	1013034	1013034	1013034
23.	Terminal Block, Room Temperature Sensor 2- position	1016018	1016018	1016018	1016018	1016018	1016018
24.	***Heating Elements	Contact factory with serial number of heater					
25.	High Temperature Vinyl	1015028	1015028	1015028	1015028	1015028	1015028
26.	Heat Storage Brick	5903010	5903010	5903010	5903010	5903010	5903010
27.	Painted Panel, Front	5943470	5943470	5943472	5943474	5943476	5943478
28.	Painted Panel, Top (DO NOT REMOVE)	5943050	5943050	5943052	5943054	5943056	5943058
29.	Painted Panel, Bottom	5943060	5943060	5943062	5943064	5943066	5943068
30.	Painted Panel, Right	5943420	5943420	5943420	5943420	5943420	5943420
31.	Painted Panel, Left	5943416	5943416	5943416	5943416	5943416	5943416
32.	Galvanized Panel, Front	5943010	5943010	5943012	5943014	5943016	5943018
33.	Galvanized Panel, Back	5943440	5943440	5943442	5943444	5943446	5943448
34.	Galvanized Plate, Bottom	5943430	5943430	5943432	5943434	5943436	5943438
35.	Galvanized Plate, Right	5943424	5943424	5943424	5943424	5943424	5943424
36.	Galvanized Base Tray	5943450	5943450	5943452	5943454	5943456	5943458
37.	Base Cap for Insulation	5943130	5943130	5943130	5943130	5943130	5943130
38.	Low Voltage Raceway Cover	5943216	5943216	5943216	5943216	5943216	5943216
39.	Insulation Panel, Front	1053010	1053010	1053012	1053014	1053016	1053018
40.	Insulation Panel, Back	1053010	1053010	1053012	1053014	1053016	1053018
41.	Insulation Panel, Bottom	1053020	1053020	1053022	1053024	1053026	1053028
42.	1 1/2" Blanket Insulation, Outer	1050005	1050005	1050005	1050005	1050005	1050005
43.	1 1/2" Blanket Insulation, Inner	1050004	1050004	1050004	1050004	1050004	1050004
44.	1" Blanket Insulation, Base	1050066	1050066	1050067	1050068	1050069	1050070
45.	Grill End Bracket, Right	5943426 (includes one right and one left grill end bracket)					
46.	Grill End Bracket, Left						
47.	Grill Support Rail	5943024	5943024	5943024	5943024	5943024	5943024
48.	Grill Slats	5943480	5943480	5943482	5943484	5943486	5943488
49.	Aluminized Air Channel, Top Back	5949060	5949060	5949062	5949064	5949066	5949068
50.	Aluminized Air Channel, Right	5943464	5943464	5943464	5943464	5943464	5943464
51.	Aluminized Air Channel, Left	5949028	5949028	5949028	5949028	5949028	5949028
52.	Mounting Hardware Package	1190038	1190032	1190032	1190032	1190032	1190032
53.	Wall Support Bracket	N/A	5943490	5943492	5943494	5943496	5943498
54.	Security Base Shell	5942114	N/A	N/A	N/A	N/A	N/A
55.	Security Base Filler	1190023	N/A	N/A	N/A	N/A	N/A
56.	Wiring Harness (umbilical cord) Conduit	N/A	1040800	1040800	1040800	1040800	1040800
57.	Cord Assembly, Plug-in	1015000	N/A	N/A	N/A	N/A	N/A
58.	Remote Room Temperature Sensor (optional)	1302024	1302024	1302024	1302024	1302024	1302024
59.	Time Clock Module (optional)	1301014	1301014	1301014	1301014	1301014	1301014

\*1012090R is a direct replacement in Model 2104.

\*\*Manual and auto reset limits are not interchangeable. Verify serial number and/or style of limit switch before ordering.

\*\*\*Optional voltages or wattages are available. Contact factory with model number and serial number of the heater.

# INTERNAL LINE VOLTAGE WIRING DIAGRAMS

Models 2102, 2103, 2104, 2105, and 2106



Connections shown are for systems with a 208/240V blower. If utilizing a 115V blower and controls circuit, the blue/black (L1) connection must be the ungrounded (hot) conductor of the power feed. Refer to the Unit Identification Label on the lower left side panel for proper blower and heating element voltages.

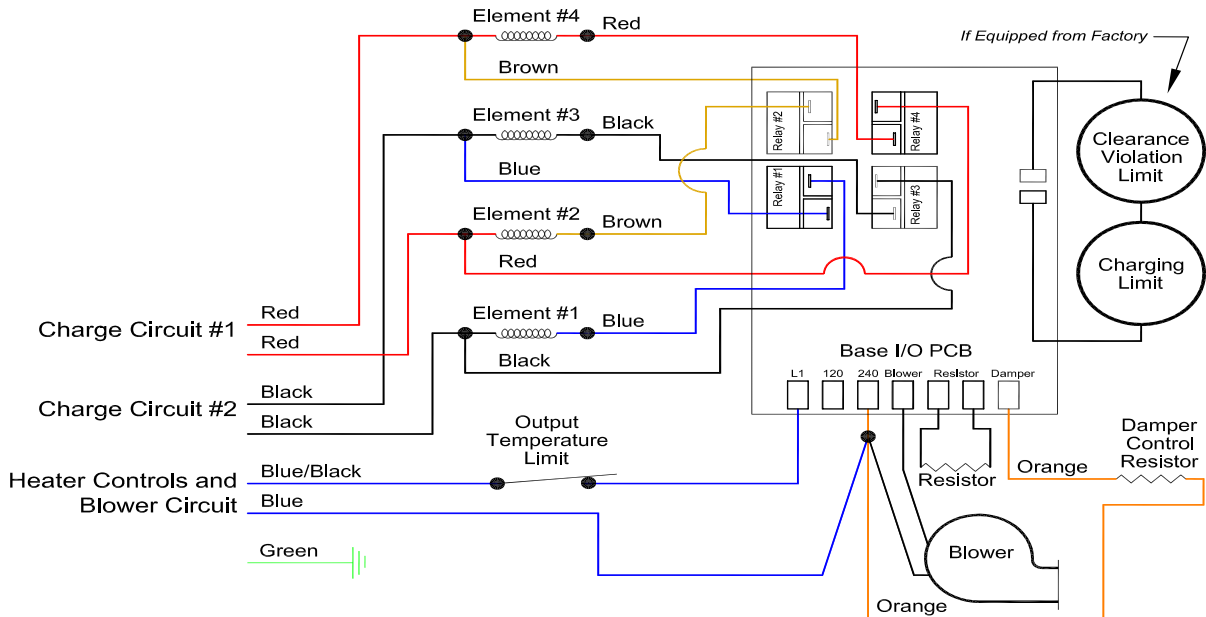

Model 2102 (plug-in heater)



Connections shown are for systems with a 115V blower. Refer to the Unit Identification Label on the lower left side panel for proper blower and heating element voltages.

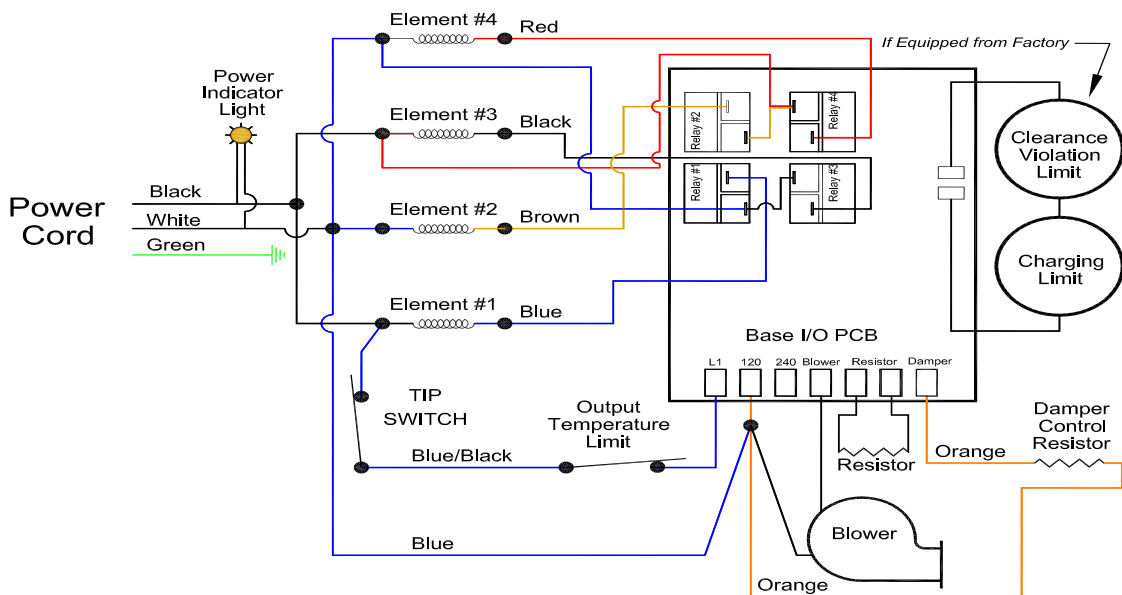

# MANUAL RESET LIMIT CONTROLS

	<h2 style="margin: 0;">WARNING</h2>	<p><b>Risk of electric shock. Do not disassemble the heater. There are no user serviceable parts inside.</b></p>
---	-------------------------------------	--

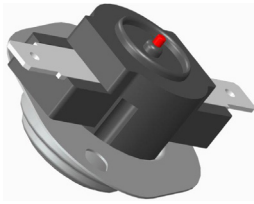

The discharge air high limit, the core charging high limit, and the clearance violation limit switches are all manual reset limit controls installed for safety purposes. If one of these limit controls opens, it must be manually reset before operating the heater. To reset the limit controls, press and release the reset button located in the middle of the control.

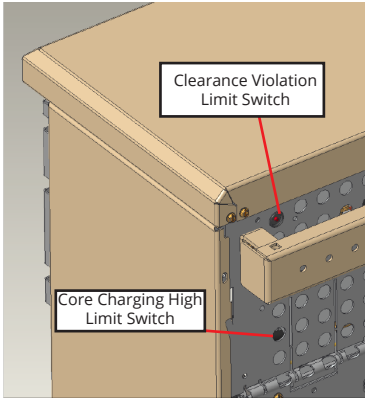

**Clearance Violation Limit:** Located inside the heater in the upper back corner of the electrical compartment. Activation of this control would be indicated by the display scrolling “core” “fail” and would indicate that the heater has malfunctioned. This limit can be reset at the back of the heater. If problem persists, contact service technician to troubleshoot and repair the root cause of the condition.

**Core Charging High Limit:** Located inside the heater at the back of the electrical compartment. Activation of this control would be indicated by the display scrolling “core” “fail” and would indicate that the heater has malfunctioned. Contact service technician to troubleshoot and repair the root cause of the condition.

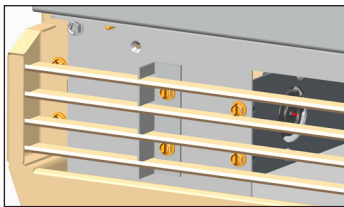

**Discharge Air High Limit:** The discharge air high limit is located in the lower left portion of the grill area and can be accessed through the grill. Activation of this control would be indicated by a blank display screen. This control can be reset by pressing the button on the limit control located just inside of the discharge air grills. If this control activates multiple times, contact a qualified service technician for repairs.

## INTERNAL LOW VOLTAGE WIRING DIAGRAM

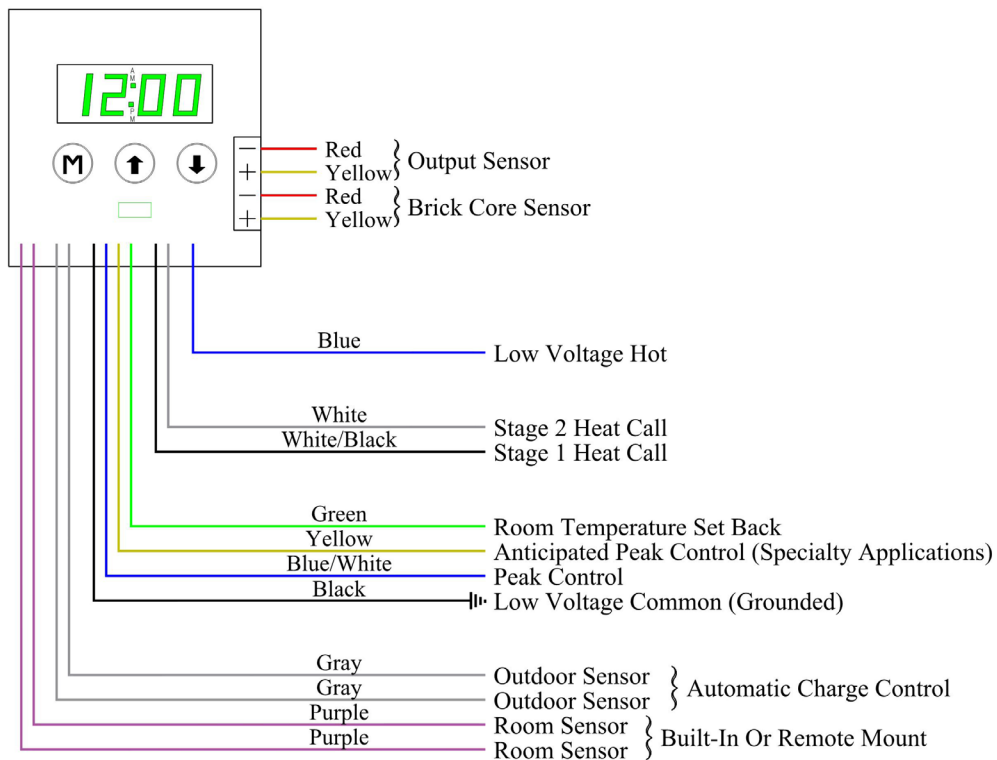

## HELP MENU

The 2100 series room heating unit contains a Help Menu which may be accessed by pressing and releasing the **M** button until "HELP" is displayed on the faceplate. Scroll through the menu by pressing either the up or the down arrow button.

<b>Display Reading</b>	<b>Description</b>
Fxxx	Firmware Version Number - Indicates the version of software installed.
O xx	Outdoor Temperature - Indicates current outdoor temperature as recognized by the heater.
tL:xx	Target Level - Indicates the percentage of brick core charge the heater targets during an off-peak period.
CL:xx	Charge Level - Indicates the percentage of heat storage currently in the brick core.
HE x	Heating Elements Active - Indicates the number of heating elements currently energized.
PC x	Power Line Carrier Channel - Indicates the channel on which the heater is set to receive PLC communication signal.
P x	Power Line Carrier Net Hit Rate Percentage - Indicates the percentage of "GOOD" communication packets received by the heater from the PLC transmitter system.
PS x	Indicates which Specialty Timer the system is currently using. The value displayed will be zero if the Specialty Timer is not being utilized.
CC_x	Charge Mode Operation - Indicates the charge control method being utilized during off-peak periods.
CA_x	A-Peak Mode Operation - Indicates the charge control method being utilized during anticipated peak periods.
C1_x	Specialty Timer #1 Charge Mode - Specialty Applications Only.
C2_x	Specialty Timer #2 Charge Mode - Specialty Applications Only.
HUxx	Heat Usage - Indicates the amount of input being dissipated by the system.
A_xx	Target Discharge Air Temperature - Indicates the discharge air temperature that the system is targeting.
cxxx	Compressor Output Relay Delay Timer - Indicates time remaining before heat pump compressor is energized. "c ON" indicates the heat pump is energized.
°128	Forecast Outdoor Temperature- Specialty Applications Only

## ERROR CODES

2100 Series heaters have an on-board diagnostic system to monitor various operating conditions. If operating conditions move outside the normal operating range, an error code will be displayed on the faceplate. If there are multiple errors simultaneously, only the highest priority error code will be displayed. Once corrected, the next highest priority code will be displayed. Error codes will be displayed on the faceplate as "Er—" (i.e. Er05).

<b>Error Code</b>	<b>Description</b>
01	Core temperature sensor reading is out of normal range. An open, shorted, or otherwise defective sensor or a circuit board which is out of calibration could cause this.
02	Contact a qualified service technician.

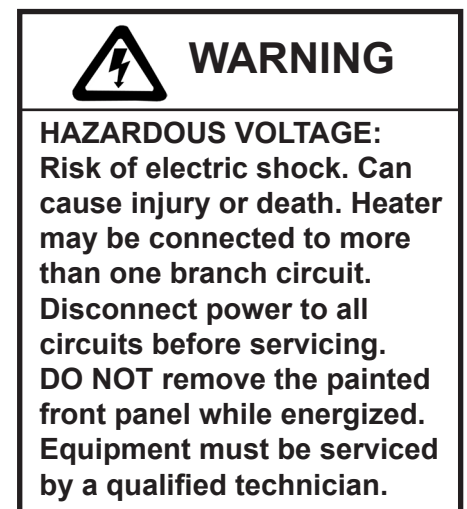



<b>Error Code</b>	<b>Description</b>
03	Room thermistor temperature is out of normal range. This may indicate an open thermistor, a short in the wiring, or a circuit board which is out of calibration.
04	Discharge air temperature is out of normal range. Ensure proper operation of the damper system. Also, an open, shorted, or otherwise defective output sensor or a circuit board which is out of calibration could cause this.
05	Outdoor sensor (direct wired) temperature reading is out of normal range. The thermistor circuit may be open or shorted, the processor control board may be out of calibration, or there may be an incorrect value in L035.
06	Outdoor sensor temperature from the transmitting device (PLC system) is out of normal range. Check the outdoor sensor attached to the transmitting device and the transmitter for proper operation.
07	Processor control board temperature sensor is out of normal operating range. Verify that none of the clearances have been violated and inspect the condition of the processor control board.
08	Currently not utilized.
09	Currently not utilized.
10	Discharge air temperature has exceeded maximum operating temperature.
20	There is no communication occurring between the Base I/O board and the processor control board. This may be caused by a defective board interface cable or an unresponsive Base I/O board.
21	Contact a qualified service technician.
22	Contact a qualified service technician.
23	There is no communication occurring with the Steffes Time Clock Module.
24	Temperature sensor offset/reference is out of range and indicates one of the sensors may be shorted to ground or the processor control board may be out of calibration.
25	Contact a qualified service technician.
26	Insufficient Main Control Board Memory. Contact a qualified service technician.
27	Insufficient Permanent Memory. Contact a qualified service technician.
28	Permanent memory change has been made. Press the <b>M</b> button to accept. As this error message indicates a change has been made to the software program, it is important to verify that all location settings are correct for the application.
29	On-board communication system is not fully operable. Contact a qualified service technician.
30	Base I/O circuit board is in test mode. Verify jumper configuration.
31	Contact a qualified service technician.
39	Indicates the value in Configuration 2 (C002) has been set to a value greater than the value in Configuration 1 (C001). The system will not charge until the value in C002 is set lower than C001.
40	Press and release the <b>M</b> button to clear the error. If the error code reappears, contact a qualified service technician.
41-44	Contact a qualified service technician.
Cold Core	The temperature of the brick core has dropped below 40 degrees or the brick core sensor may be open. Verify that the brick core sensor wiring is connected properly.
Core Fail	Core charging and/or clearance violation high limit switch may be open. Reset the clearance violation limit, if open. Reference manual reset limit controls on page A.05 for more information.
PLC Fail	The system is configured for power line carrier; however, is not receiving a valid power line carrier communication signal.

## HINGING THE RIGHT SIDE PANEL

For ease in servicing, the right side panel of the 2100 Series room heating unit hinges open. Follow the instructions below to hinge the right side panel:

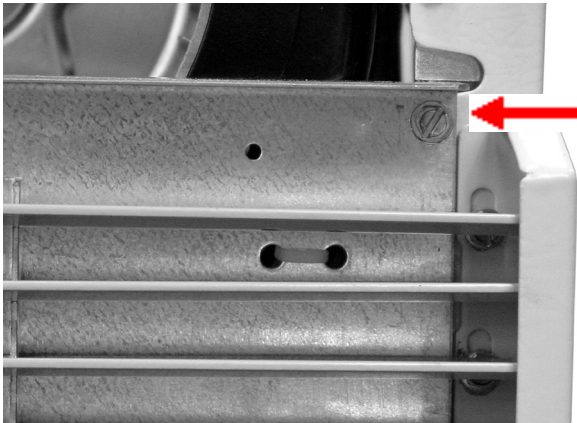

1. With the painted front panel off, remove the screw located above the grill slats on the lower right side of the heater.

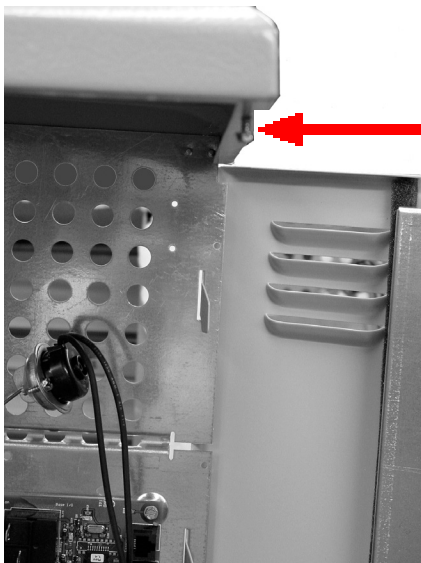

2. Loosen the screw located at the top right corner of the electrical compartment.

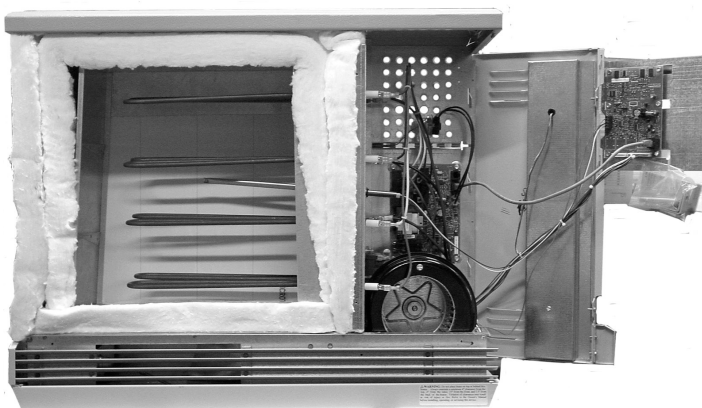

3. Push out on the right side panel.

## GLOSSARY

**Anticipated Peak** ~ Used only by certain power companies as an alternative method of storing heat in the brick core. Indicated by an "A" on the system display. Also referred to as "Pre-Peak".



**Automatic Charge Control** ~ Method of brick core charge regulation where a sensor monitors outdoor temperature to automatically adjust the brick core temperature.

**Brick Core Charge Level** ~ The amount of heat currently stored in the brick core of the heater.

**Charge Period** ~ Off-peak time in which the system is allowed to store heat in its brick core. Indicated by a "C" on the system display.

**Control Panel** ~ Contains the buttons to adjust and the display to indicate heater functions. Located on the front of the heater in the upper right corner.

**Control Period** ~ On-peak time in which the system is not allowed to store heat in its brick core. Indicated by a "P" on the system display.

**Edit Mode** ~ Process of changing or viewing the values in a microprocessor location. This is accomplished with the use of the **M** (mode) button, the  (up arrow) button, and the  (down arrow) button.

**Location (Function)** ~ Where the specific operating information of the heater is stored. These locations are part of the heater's microprocessor and are accessed through the heater's control panel. Displayed as an "L" on the faceplate when in the edit mode.

**Location Value** ~ The specific information set and stored in a location on the heater's microprocessor which defines heater operation. A value for a specific location is accessed through the heater's control panel.

**Manual Charge Control** ~ Method of brick core charge regulation where the owner must periodically adjust the brick core temperature setting in relation to the outdoor temperature.

**Microprocessor** ~ Device on the circuit board of the heater which stores and processes the information for controlling the operation of the heater.

**Off-peak** ~ The time during the day or night when the power company can supply electricity more economically and may offer a special incentive such as a reduced electric rate or billing credits for the electricity consumed during this time. Typically, electrical usage is not controlled during an off-peak time. (The heater will provide heat to satisfy comfort requirements during this time as well as charge or store heat in its brick core.)

**On-peak** ~ The time during the day or night when the power company experiences a high demand for electricity. To limit demand, certain appliances are controlled to avoid usage by them and/or a premium for the electricity consumed during this time may be charged to discourage electrical usage. (The heater is not allowed to charge or store heat in its brick core during peak periods. Heating requirements are satisfied by the heat stored in its brick core during the previous off-peak period.)

**Outdoor Sensor** ~ Device that senses outdoor air temperature and communicates this information to the heater.

**Pre-Peak** ~ Used only by certain power companies as an alternative method of storing heat in heater's brick core. Also referred to as "Anticipated Peak".

**Room Temperature Set Point** ~ The desired room temperature the heater is to maintain as set by the owner. If the room thermostat senses a temperature below this point, the heater's blower will come on and extract heat from the brick core.

# **Warranty**

---

Registering your purchase is an essential step to ensure warranty coverage. A Warranty Registration card is included with the Owner's Manual. Simply complete, detach the bottom portion, and return the card today. Retain the top portion of the card for your files.

## **WARRANTY STATEMENT**

Steffes warrants for a period of five (5) years following delivery, limited to seven (7) years from date of manufacture, of any goods provided under this Agreement that the goods purchased hereunder will be of merchantable quality, free from defects in material and workmanship, and that the goods provided will be new and conform to the mechanical and performance specifications referenced in any drawings provided by Steffes. Customer shall promptly provide notice to Steffes of any goods which do not comply with such warranty.

THE WARRANTIES SET FORTH HEREIN ARE STEFFES' SOLE AND EXCLUSIVE WARRANTIES, AND THEY ARE MADE IN LIEU OF ALL OTHER WARRANTIES. THERE ARE NO OTHER WARRANTIES, EXPRESS OR IMPLIED, WHETHER ARISING BY OPERATION OF LAW, STATUTE, USAGE OF TRADE, CUSTOM, COURSE OF DEALING OR PERFORMANCE, THE PARTIES' CONDUCT OR OTHERWISE, FOR ANY PRODUCTS, SERVICES OR OTHER ITEMS SOLD OR FURNISHED BY STEFFES. WITHOUT LIMITING THE GENERALITY OF THE FOREGOING, AND EXCEPT TO THE EXTENT EXPRESSLY STATED HEREIN, STEFFES DISCLAIMS ALL IMPLIED WARRANTIES OF MERCHANTABILITY AND FITNESS FOR A PARTICULAR PURPOSE AND, EXCEPT TO THE EXTENT EXPRESSLY STATED HEREIN, THERE ARE NO WARRANTIES WHICH EXTEND BEYOND THE DESCRIPTION ON THE FACE OF THIS DOCUMENT. STEFFES SHALL NOT BE LIABLE FOR ANY LOSSES, CLAIMS, DAMAGES OR LIABILITY RELATING TO LOST PROFITS OR OTHER CONSEQUENTIAL, INCIDENTAL, EXEMPLARY, PUNITIVE OR INDIRECT DAMAGES IN CONNECTION WITH OR RELATING TO GOODS PROVIDED HEREUNDER.

If the goods fail to meet the warranty requirements set forth herein, as mutually agreed by both Parties, excluding goods which have been subject to misuse, abuse, negligence, accident, improper maintenance or improper operations, Steffes shall: repair or replace the product or part(s) only which prove to be defective under normal use. The Customer shall be responsible for any labor costs associated with the repair or replacement of the product or part(s), including the cost of returning the defective product or part(s) to Steffes.

This Warranty is void if the product is moved from the premises in which it was originally installed. This Warranty shall not apply to any product or part which has been altered in any respect, or improperly installed, serviced or used, or has been subject to accident, negligence, abuse or misuse.

The Customer assumes all risk and liability whatsoever resulting from the use of this device. In no event shall Steffes be liable for any indirect, special or consequential damages or lost profits.

This Limited Warranty contains the complete and exclusive statement of Steffes' obligations with respect to this device and any parts thereof. The provisions hereof may not be modified in any respect except in writing signed by a duly authorized officer of Steffes.

*Thank you for purchasing Steffes ETS heating equipment. We welcome your comments relating to the heater and this manual. Enjoy your new purchase!*

 **STEFFES** 3050 Hwy 22 North • Dickinson, ND 58601-9413 • [www.steffes.com](http://www.steffes.com)