



OWNER'S AND INSTALLER'S MANUAL

for

Comfort Plus Hydronic Heating Systems

Equipped with Variable Speed
for Optional Air Handler



**Models:
5120, 5130,
& 5140**

Applicable to Software Version 2.00 - 2.19



IMPORTANT

- The equipment described herein is intended for installation by a qualified technician in compliance with applicable local, state, and national codes and requirements.
- To ensure proper installation and operation of this product, completely read all instructions prior to attempting to assemble, install, operate, maintain or repair this product. Upon unpacking of the system, inspect all parts for damage prior to installation and start-up.
- This manual should be retained by the owner upon completion of the installation and made available to service personnel as required.
- This appliance is not to be used by persons (including children) with reduced physical, sensory or mental capabilities or lack of experience and knowledge, unless they have been given supervision and instruction on the safe use of the appliance and the hazards involved. Children shall not play with the appliance.
- **Disclaimer:** In compiling this manual, Steffes has used its best judgement based upon information available, but disclaims any responsibility or liability for any errors or miscalculations contained herein, or any revisions hereof, or which result, in whole or in part, from the use of this manual or any revisions hereof.

After the heating system is installed, Steffes disclaims any responsibility or liability for mold/mildew growth and/or any damages caused by either. We strongly recommend that the user follow the moisture, mold and mildew prevention guidelines of the Environmental Protection Agency (EPA), available at <http://www.epa.gov>.

For Customer Use

Please record your model and serial number below. This number is found on the identification label located on the lower left side of the Comfort Plus Hydronic heating system. Retain this information for future reference.

Model No. _____

Serial No. _____

RECOGNIZE THESE SYMBOLS AS SAFETY PRECAUTIONS



It is important, both for your personal safety and to avoid possible damage to the equipment and your property, that you observe the safety instructions given following these symbols.

SAFETY PRECAUTIONS

1. Install all ceramic heat storage brick before energizing the system. Failure to do so may result in equipment damage.
2. Install the pressure relief valve provided before operating this heating system.
3. Keep combustible materials away from this system. Storing explosive or flammable materials near this heating system can result in an explosion or fire.
4. Follow all placement and clearance requirements as specified in this manual. (Page 3.02)
5. Make sure nothing is placed or stored on top of this system.
6. Disconnect power to all circuits before servicing as this heating system may be connected to more than one branch circuit.
7. Use caution when working around the heating system as inlet and outlet piping can be very hot.
8. Installation of and/or service to this system should be performed by a qualified technician in compliance with information contained herein and with national, state, and local codes and requirements.
9. A repeated message display of “CORE FAIL” indicates a need for service by a qualified technician.

WARNING



Risk of explosion. Can cause injury or death. Operating the system without the pressure relief valve installed can cause an explosion. Connect the pressure relief valve in a vertical, upright position with the supplied fittings. DO NOT modify this assembly. DO NOT cap, plug, or otherwise obstruct the outlet of the pressure relief valve.



Risk of fire. Can cause injury or death. Violation of the clearance requirements can cause improper operation of the equipment. Maintain the placement and clearance requirements specified.



Risk of personal injury. Plumbing and other surfaces can be hot. Use caution when working near the system.

SAFETY DEVICES

The Comfort Plus Hydronic incorporates safety devices to ensure normal operating temperatures are maintained. The chart below describes these safety devices:

DEVICE NAME	FUNCTION	LOCATION ON SYSTEM
Core Charging High Limit Switches (Auto Reset)	These limit switches monitor brick core charging and interrupt power to the heating elements if the normal operating temperature is exceeded.	In the limit zone on the left side of the brick storage cavity.
Heat Exchanger Limit Switch (Manual Reset)	This linear limit switch monitors the temperature of the water in the exchanger and interrupts power to the core blower if a water temperature of 250°F/121°C is exceeded. If this limit switch opens, contact a qualified service technician.	Inside base on left side.
Outlet Water Temperature Limit Switch (Auto Reset)	This linear limit switch monitors the temperature of the water in the exchanger and interrupts power to the core blower if a water temperature of 225°F/107°C is exceeded.	Inside base on left side.
Pressure Relief Valve	If the water pressure exceeds 30 psig, the pressure relief valve opens. Once water pressure of less than 30 psig is achieved, the valve closes.	Factory provided, field installed to outlet port of furnace.



Table of Contents

Operation

General Operation	1.01
System Use During Construction Phase	1.01
System Start-up	1.01
Turning System "OFF" and "ON"	1.01
Control Panel	1.02
Operating Status	1.02
Room Temperature Control	1.03
Brick Core Charge Control	1.03
Charge Control Override	1.03
Maintenance and Cleaning	1.03

Optional Accessories

Single Electrical Feed Kit	2.01
Primary Loop Kit	2.01
Static Heat Recovery Unit	2.01
Comfort Plus Stand	2.02
Air Handler	2.02

Installation

Shipping and Packaging	3.01
Placement and Clearance Requirements	3.02
Initial Set-up	3.03
Brick Loading	3.03-3.04
Heating Element and Air Channel Installation	3.04
Brick Core Temperature Sensor Installation	3.05
Line Voltage Electrical Connections	3.05-3.06
Low Voltage Electrical Connections	
Peak Control	3.07-3.08
Outdoor Temperature Sensor	3.08
Room Thermostat	3.09-3.10
Pressure Relief Valve Installation	3.11
Plumbing	3.11-3.13
Auxiliary Load Control	3.13
Configuration Menu	3.14-3.15
Installer's Final Check-out Procedure	3.16

Appendix

Specifications	A.01
Parts Diagram	A.02
Parts List	
A.03-A.04	
Internal System Wiring Diagrams - Line Voltage	A.05-A.07
Internal System Wiring Diagram - Low Voltage	A.08-A.09
Help Menu	A.10
Error Codes	A.10-A.11
Disassembling the Comfort Plus Hydronic System	A.12
Glossary	A.13

Warranty

1

Operation

GENERAL OPERATION

The Steffes Comfort Plus Hydronic heating system stores off-peak electricity in the form of heat. Off-peak electricity is available during times of the day or night when electricity is plentiful and the power company may supply it at a lower cost.



Operation of the Comfort Plus Hydronic is automatic. When off-peak hours are available, the system converts electricity to heat which is then stored in its ceramic brick core. The amount of heat stored in the brick core varies in relation to outdoor temperature, owner preference, utility peak conditions, and the requirements of the space being heated.

A heat call from the room thermostat energizes the primary water loop pump. The variable speed core blower automatically adjusts its speed to achieve the desired outlet water temperature. The heated water is then pumped to the area (zone) from which the heat call originated.

The versatility of this system allows it to fit many applications. The Comfort Plus Hydronic is designed for use as either the sole heating source (“stand alone” furnace) or as a supplement to ducted heating systems such as heat pumps.

SYSTEM USE DURING CONSTRUCTION PHASE

Like most heating equipment manufacturers, Steffes strongly recommends that “Construction Heating Units” be used instead of the permanent heating system during the construction phase of a new home. Use of the permanent heating system during the construction phase may contaminate the duct system and/or internal areas of the heating system. This may cause poor indoor air quality issues and/or improper system operation once the home is completed. A suitable alternative heating system should be used during the construction phase.

SYSTEM START-UP

On start-up of the Comfort Plus Hydronic system, odors relating to first time operation of the heating components may be experienced. Allow the system to charge to its maximum brick core charge level, on start-up, to expel these odors. If the Comfort Plus Hydronic has not been used for an extended period of time, dust may accumulate in the system. Upon restart, there may also be an odor as these dust particles are expelled.

During operation, the system may produce minor expansion noises. These noises are the result of the internal components reacting to the temperature changes.

TURNING SYSTEM "OFF" AND "ON"

The Comfort Plus Hydronic element (charging) circuits may be turned “OFF” by switching all of the 60 AMP breakers located on the front of the electrical panel to the DOWN position. To turn the element circuits “ON”, switch the 60 AMP breakers to the UP position.

NOTE: *The 60 AMP breakers MUST all be turned "ON" or all turned "OFF". The 15 AMP breaker MUST remain "ON" to operate controls in the system if:*

- *using the Comfort Plus Hydronic in conjunction with a heat pump or air conditioner.*
- *using the Comfort Plus Hydronic to control other loads.*
- *using the optional Steffes Time Clock Module.*
- *using the Comfort Plus Hydronic to exercise the pumps during periods of inactivity.*

CONTROL PANEL

Operation of the Comfort Plus heating system is automatic. Operational function settings are stored in a microprocessor on the processor control board. These settings are modified, if necessary, through the Configuration Menu as described on Pages 3.14-3.15. In most applications, the system is configured upon installation and no further changes are required.

Four-Digit LED Display

The four digit LED displays specific operating information. During the configuration process, the configuration number and the values set in these configurations are displayed for viewing and adjusting purposes.

AM and PM Indicator Lights

The AM and PM indicator lights are only utilized if the Steffes Time Clock Module is being installed and using 12 hour time display. With this module installed, the system displays time on AM/PM intervals. The light flashes next to the active designator/symbol. The system can be configured to display military time, in which case, both the AM and PM lights illuminate.

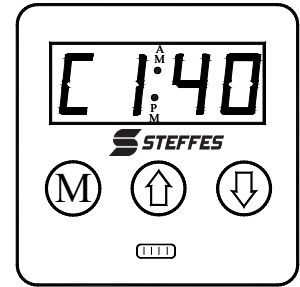

CONTROL PANEL

M Mode (Edit) Button

Used to access menus on the system (i.e. Help Menu or Configuration Menu) and to allow modifying of configuration settings.

Up and Down Arrow Buttons

Used to scroll up or down when viewing or modifying operating functions.

Interface Port

Allows technician external access for advanced operating modes, updating software, and troubleshooting.

IMPORTANT

Editing operating information may alter the performance and operation of the system.

OPERATING STATUS

The four digit LED will display various operating information as described below. Press and release the up arrow to view this data.



Operating Mode and Outlet Water Temperature - indicates the current operating mode followed by the outlet water temperature.

C = Off-Peak (Charge) Time

P = On-Peak (Control) Time

A = Anticipated Peak Time

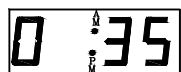

Outdoor Temperature - indicates current outdoor temperature.



Heat Call Status - indicates the current heat call status as determined by the room thermostat(s). The faceplate displays the highest heat call value present. If receiving a Stage 1 Forced Air Heat Call and a Hydronic Heat Call, the display will read "HC_3". Reference the Room Thermostat section for more information on Heat Call Status displayed.

NOTE: A bar illuminates on the lower portion of the display's third digit whenever the heating elements are energized.

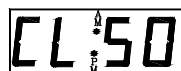

Brick Core Charge Level - "CL" (charge level) followed by a number, indicates the current percentage of heat stored in the brick core. "CL:_" represents zero percent and "CL: F" represents a full core charge level.



Targeted Brick Core Charge Level - "tL" (target level) followed by a number, indicates the current percentage of brick core charge being targeted by the system. A display of "tL:_" indicates a target level of zero percent and "tL: F" indicates a full core charge target level.

ROOM TEMPERATURE CONTROL

Room temperature is adjusted at the wall thermostat(s). A heat call from the room thermostat energizes the primary water loop pump. The variable speed core blower automatically adjusts its speed to achieve the desired outlet water temperature. The heated water is then pumped to the area (zone) from which the heat call originated.

In heat pump applications, a heat call from the room thermostat first utilizes the heat pump's heating capacity to satisfy comfort requirements. As the outdoor temperature declines and the heat pump's heating capacity begins to diminish, the Comfort Plus Hydronic modulates heat to help maintain a comfortable air temperature in the duct.

BRICK CORE CHARGE CONTROL

The amount of heat stored in the brick core of the Comfort Plus Hydronic system is regulated automatically in relation to outdoor temperature and the heating requirements. The outdoor sensor, supplied with the system, monitors outdoor temperature. As the outdoor temperature decreases, heating requirements increase, and the Comfort Plus Hydronic system stores more heat accordingly.

CHARGE CONTROL OVERRIDE

The Comfort Plus is equipped with a charge control override feature that allows the user to force the system to target a full core charge level. This override can be initiated or cancelled at any time. If an override is initiated, the system targets a full core charge level during the next off-peak period. It continues to charge during off-peak hours until the system achieves full (maximum) core charge or until the override is cancelled. Once full charge is achieved or the override is cancelled, the system charges according to its standard configuration.

Initiating the Override Feature

- Step 1** Press and hold the **M**, the up arrow, and the down arrow buttons at the same time.
- Step 2** The faceplate will flash "FULL" and "ON". Continue to hold the three buttons until "ON" displays continuously on the faceplate.
- Step 3** Release the buttons. The override is now enabled. The faceplate will return to displaying its standard operating mode.

Manual Cancellation of the Override Feature

- Step 1** Press and hold the **M**, the up arrow, and the down arrow buttons at the same time.
- Step 2** The faceplate will flash "FULL" and "OFF". Continue to hold the three buttons until "OFF" displays continuously on the faceplate.
- Step 3** Release the buttons. The override is now cancelled. The faceplate will return to displaying its standard operating mode.

MAINTENANCE AND CLEANING

General cleaning of the system's cabinet should be conducted at the user's discretion. It is important to monitor water levels/pressure (PSI) as low water levels cause poor performance and possible damage to the system. Ask the installer of the equipment for information on how to measure these levels.

When using the Steffes Air Handler with the Comfort Plus Hydronic System, periodically check and replace the air filter.

If a heat pump or air conditioner is interfaced with the Comfort Plus Hydronic, the indoor coil of these devices should be cleaned periodically, to maintain system efficiency. Follow the manufacturer's cleaning recommendation for these devices. Regular replacement of the air filter and cleaning of coils will provide better airflow and optimum system efficiency.

2

Optional Accessories

SINGLE ELECTRICAL FEED KIT

The Steffes Comfort Plus systems have built-in circuit breakers. They are factory configured to be field connected to multiple line voltage circuits. If single feed to the element and blowers/control circuits is desired, the single feed kit is available to allow the system to be powered with one, larger line voltage circuit. Contact the factory for ordering details.

NOTE: *When using single feed, the neutral conductor MUST be sized in accordance with all applicable local, state, and national codes and regulations.*



PRIMARY LOOP KIT

The Comfort Plus Hydronic system requires a primary water loop which serves to regulate heat transfer from the unit's heat exchanger. To minimize installation time and costs for field design and engineering of this loop, Steffes offers a primary loop kit. The kit contains the components generally installed with hydronic heat systems.



Order Item #1302115

Features:

- ◆ Includes a 5-gallon diaphragm type expansion tank, Taco 007 single feed 115VAC pump, air separator, air vent, pressure gauge, and pump connection conduit and fittings.
- ◆ Contains the appropriate valves to bleed air from the system during filling along with automatic purge during system operation and draining.
- ◆ Incorporates isolation flanges for quick and easy servicing of the primary loop pump (circulator).
- ◆ Offers troubleshooting isolation between the heating system and secondary zones.

STATIC HEAT RECOVERY UNIT

NOTE: *In applications using the Steffes Air Handler, the static heat recovery unit would not be used.*

During operation of the Comfort Plus Hydronic system, some heat from the brick core storage will radiate through its outer panels. If the system is located in an area with minimal heating requirements, such as a utility room, the static heat recovery unit can maximize the system's efficiency by transferring this static heat to a more desirable location.

Features:

- ◆ Connects directly to the Comfort Plus Hydronic system to interface with the internal controls of the system for automatic operation.
- ◆ Specifications:
 - Wattage: 130 WATTS
 - Motor: .1 HP, 60 HZ
 - Voltage: 208/240 VAC
 - Maximum Static Pressure: .15 inches Water Column
 - CFM @.15 SP: 130 CFM

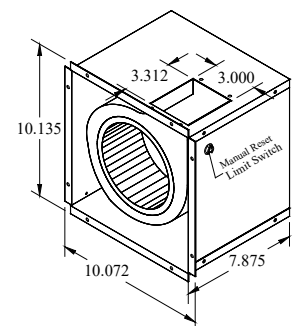

Order Item #1302110

When installing the Static Heat Recovery Unit, Steffes recommends installing a low voltage cooling thermostat, connected between R and G on the low voltage terminal block, to maintain a mechanical room temperature less than 85°F/29°C.

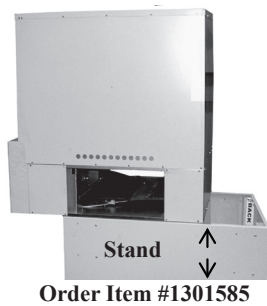

COMFORT PLUS STAND

Some applications (such as garages) may require that the heating appliance be elevated in order to meet building codes. The Steffes Comfort Plus stand elevates the 4100 or 5100 series Comfort Plus system 18". This stand is shipped as a kit and requires field assembly.

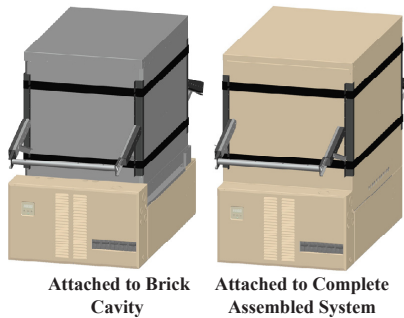

LIFTING HANDLES

To make it easier for installers to handle and move the Comfort Plus furnaces, Steffes offers special lifting handles designed specifically to fit around the furnace's brick storage module. The handles allow 2 to 4 people to more easily lift the furnace and move it to its installation site.

Order Item #1302122

AIR HANDLER

The Steffes Air Handler includes a return plenum, supply air blower, water coil, and air filter. The air handler's variable speed blower incorporates an ECM motor that automatically adjusts its speed to achieve the appropriate CFM for the thermostat input received. Benefits include:

- Quiet operation
- Better dehumidification
- Greater operating efficiency by consuming less energy during normal operating mode
- In continuous fan mode, low speed energy savings can be greater than 70% in comparison to a fixed motor speed
- Interfaces with single or multi-speed air conditioners or heat pumps. With multi-speed systems, it operates at a lower speed while higher speeds may occur on extremely hot or cold days.
- Staged heating and cooling eliminates temperature swings, enhances comfort and optimizes efficiency.
- Improved air filtration in continuous fan mode
- Constant air flow over a wide range of static conditions, even if filters are dirty or registers are closed.

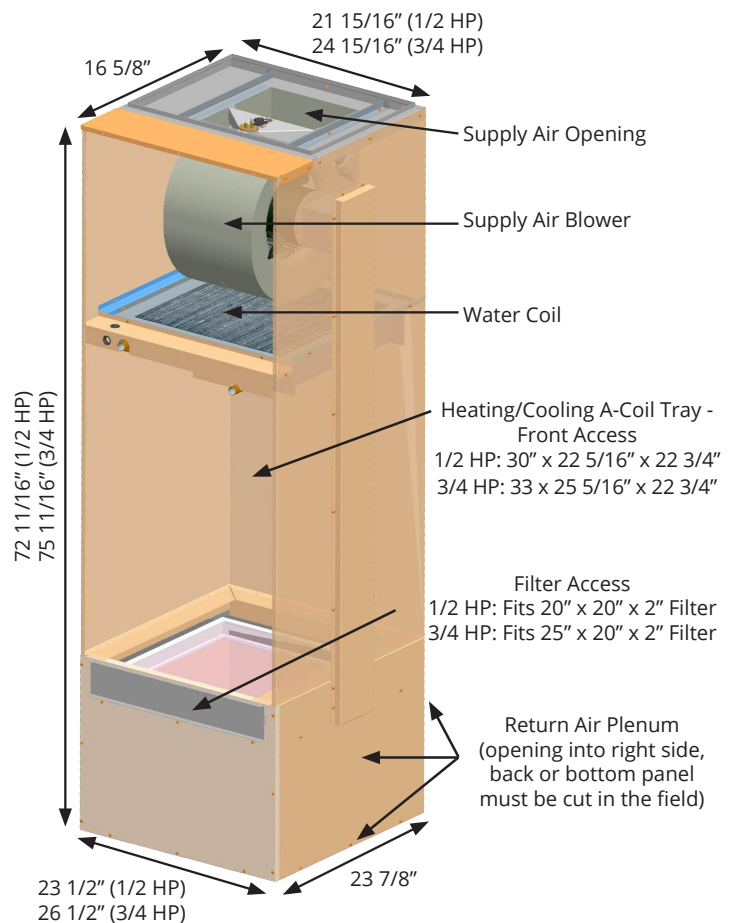

AIR HANDLER SPECIFICATIONS

	1/2 HP, 60 HZ	3/4 HP, 60 HZ
Order Item Number	1302132	1302134
Approximate Weight	200 lbs	225 lbs
Maximum Static Pressure (inches water column)	.75 inches H ₂ O	.75 inches H ₂ O
Maximum Water Coil Output	60,000 BTU/hr	90,000 BTU/hr
Maximum Outlet Temperature	120°F/49°C	120°F/49°C
A-Coil Tray Dimensions (H x W x D)	30" x 22 5/16" x 22 3/4"	33" x 25 5/16" x 22 3/4"
Voltage	240/208 VAC	240/208 VAC
Wattage	560W	1,050W
CFM ratings	1000, 1200, 1400, 1600	1200, 1400, 1600, 2000

1/2 HP variable speed accommodates most 1.5 to 4 ton heating/cooling systems. 3/4 HP variable speed accommodates most 3 to 5 ton heating/cooling systems

3

Installation



CAUTION

Risk of sharp edges. Can cause personal injury. Use caution when installing and/or servicing equipment.

SHIPPING AND PACKAGING

The Comfort Plus Hydronic should always be transported in an upright position to avoid damage to internal components and insulation materials. The information below describes the items shipped with each system:

- 1** INFORMATION PACKAGE
(includes Owner's Manual, Quick Reference Guide, and Warranty Registration Card)

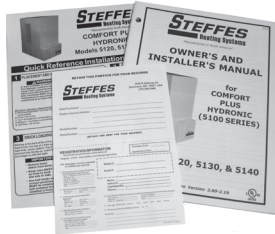

(adhered to outer side of shipping box)

- 2** HEATING ELEMENTS



MODEL	ELEMENTS
5120	8
5130	12
5140	16

(shipped in box above electrical compartment)

- 3** ELEMENT SCREW KIT AND LOW VOLTAGE BUSHING



(shipped inside the electrical compartment)

- 4** OUTDOOR TEMPERATURE SENSOR



(shipped inside the electrical compartment)

- 5** JUNCTION BOX



(shipped behind the exchanger access panel)

- 6** CERAMIC BRICK



Full Brick
(shipped separately and packaged 2 brick per package)

Half Brick
(shipped with brick and packaged in a white box consisting of 6 half brick and 1 full brick)

Model	Full Brick	Half Brick
5120	105	6
5130	150	12
5140	198	12

- 7** PRESSURE RELIEF VALVE KIT



(shipped behind the exchanger access panel)

PLACEMENT AND CLEARANCE REQUIREMENTS

The physical dimensions (Figure 1) of the Comfort Plus Hydronic along with the clearances required (Figure 2) MUST be taken into consideration when choosing its location within a structure. The best installation location for this system is in a space requiring heat, so some amount of the heating requirements can be satisfied through static dissipation from the warm outer panels of the system. Standby heat dissipation of up to 2.5kW can be experienced in normal operation. Room air should be maintained at less than 85°F/29°C.

If the Comfort Plus Hydronic is installed in an area where radiant heat coming from the system is undesired or where room temperatures may reach 85°F/29°C or greater, it is strongly recommended to install a Static Heat Recovery unit or Air Handler. Refer to pages 2.01-2.02 for information on these options.

In addition to the physical space requirements, the weight of the Comfort Plus Hydronic must be taken into consideration when selecting the installation surface. A level concrete floor is the best installation surface, but most well supported surfaces are acceptable. If unsure of floor load capacity, consult a building contractor or architect.

NOTE: *Special requirements need to be considered if placing the system in a garage or other area where combustible vapors may be present. Consult local, state, and national codes and regulations to ensure proper installation. An 18" stand (Order Item #1301585) is available to elevate the system.*



WARNING

Risk of fire. Can cause injury or death.

- ◆ **Violation of the clearance requirements or failure to provide proper ventilation can cause improper operation of the system. Maintain the placement and clearance requirements as specified and provide ventilation as necessary.**
- ◆ **Moving the system after install may result in equipment damage. Do NOT move system from original installed location.**

**DIMENSIONS
FIGURE 1**

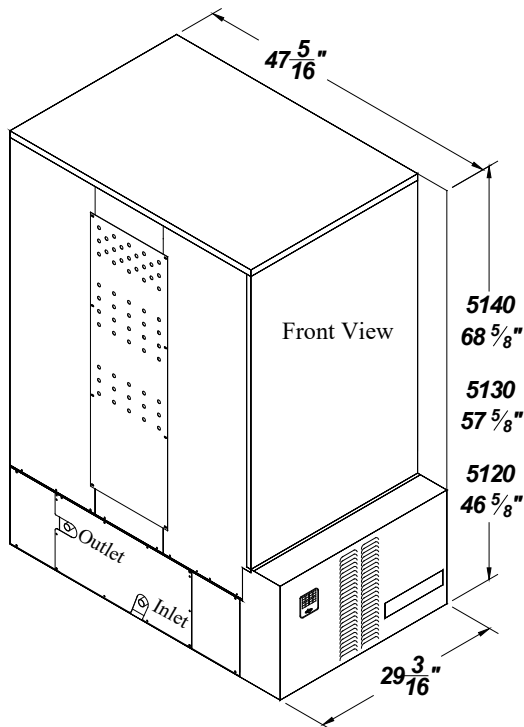

MINIMUM CLEARANCE REQUIREMENTS

- ◆ Back and Right Side = 3 inches (from combustible material)
- ◆ Bottom = 1 inch clearance (from combustible material)
- ◆ Top = 6 inches (from combustible material)
- ◆ Front = 36 inches (for ease in servicing)
- ◆ Left Side = 36 inches (for ease in servicing)

**REQUIRED CLEARANCES
FIGURE 2**

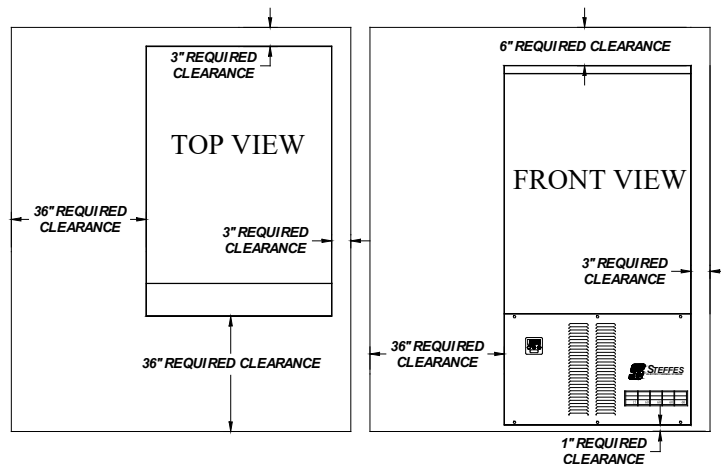

NOTE: *Minimum clearance requirements do NOT account for space needed for making electrical connections. If utilizing the Air Handler, additional space is required on the right hand side of the system.*

INITIAL SET-UP

Step 1 Remove the Information Package from the outside of the shipping box and unpackage the Comfort Plus Hydronic heating system.

Step 2 Move the heating system into its installation location. The Comfort Plus Hydronic is capable of fitting through a 30" doorway (minimum) without disassembling. If it is necessary to disassemble the system, refer to the disassembly instructions (Page A.12) in this manual.

Step 3 Once in place, adjust the leveling legs on the bottom of the system as necessary to prevent rocking. If not placed properly the system may bend or twist during the brick loading process, making element and brick core temperature sensor installation difficult.

Step 4 Remove the painted front panel of the brick storage cabinet by removing the sheet metal screws along the top, bottom, and sides of the panel. Detach by pulling the bottom of the panel forward and down.

Step 5 Locate the element wiring harnesses and brick core temperature sensor(s) behind the front panel and disconnect them from their shipping position. Carefully position them to avoid damage during brick loading.

Note: Models 5130 and 5140 have two brick core temperature sensors.

Step 6 Remove the galvanized front panel and set it aside.

Step 7 Carefully lift the two insulation blankets, one at a time starting at the bottom, and drape them over the top of the system.

Note: Use face mask, gloves, and long sleeved garments when handling insulation materials in compliance with generally accepted safety practices.

Step 8 Remove the front air channel by pulling out at the top.

Step 9 Remove the heating elements from inside the brick core cavity.

BRICK LOADING

Load the brick, one row at a time, using a left side, right side, center pattern. Start at the back of the brick core and work forward. Make sure the brick are placed so the grooved side is facing up and the ridges are on the left and right. (See Figure 5.)

BRICK INSTALLATION TIPS:

- Install bricks carefully to avoid damage to the insulation panels.
- Remove loose brick debris to prevent uneven stacking of brick, as this can make installation of the elements and the brick core temperature sensor(s) difficult.
- Brick rows MUST line up front to back and side to side.
- Half brick makes brick loading easier by evening out the stacks. Use HALF BRICK (white boxes) in the proper rows and positions as indicated in Figure 5.
- Alternate the direction of the brick's indicator in every other brick row. See Figures 3 and 4.
- All bricks in odd numbered rows (1, 3, 5, 7, 9, and 11) must have the indicator facing forward as shown in Figure 3.
- The bricks in even numbered rows will have the indicator facing back. See Figure 4.

IMPORTANT

To ensure proper operation, read and follow installation instructions carefully.

- ♦ DO NOT install the Comfort Plus Hydronic system on its shipping pallet.
- ♦ DO NOT extend the leveling legs more than one inch.
- ♦ DO use and follow generally accepted safety practices when handling insulation material.
- ♦ DO have equipment installed by a qualified technician in compliance with all applicable codes and regulations.



WARNING

Risk of fire. Can cause personal injury or death. DO NOT operate the system if damage to the insulation panels on the inner sides of the brick core occurs.

FIGURE 3

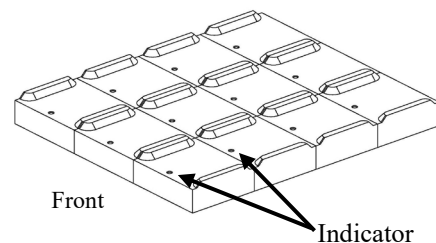

i.e.: Rows 1, 3, 5, 7, 9, and 11 in 5140

FIGURE 4

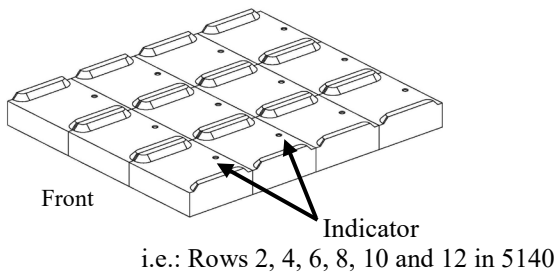
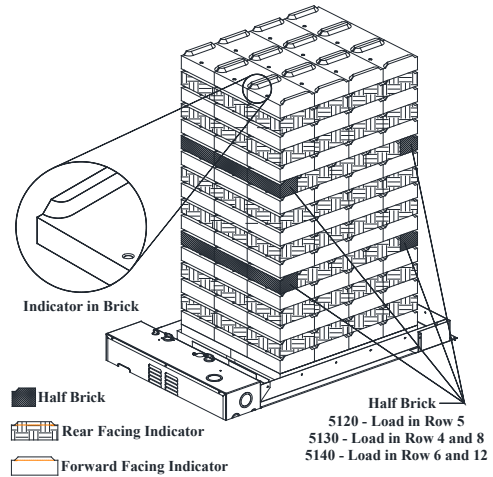

FIGURE 5



HEATING ELEMENT AND AIR CHANNEL INSTALLATION

Step 1 After all brick are loaded, insert the heating elements between the brick layers, sliding them in until the element ends embed into the side cutouts of the brick cavity. Elements **MUST** be installed with the threaded screw tabs on the wire connection terminals pointing forward and down to ease the installation of the element-to-wiring harness. Note the required clearance (Figure 6.)

Step 2 Install the front air channel by placing the bottom in first, with the air deflectors (arrow shaped pieces) facing inward. Refer to the Air Channel Placement (Figure 7) and the Parts Diagram (Page A.02) for proper placement and installation of the front air channel.

Step 3 Lower the insulation blankets back into position, one at a time. Carefully tuck the sides of this insulation into the edges, corners, and around the exposed portions of the heating element to ensure maximum efficiency.

Step 4 Reinstall the galvanized front panel by sliding the bottom of the panel inside the lower lip of the brick cavity and resting the top of the panel on the outside of the brick cavity. Secure it to the Comfort Plus Hydronic system using the screws that were originally removed.

Step 5 Remove the painted front panel of the electrical compartment by removing the screws along the edges. Locate the installation hardware package that is shipped in this compartment.

Step 6 Carefully route the element wiring harnesses and connect them to the heating elements, using the screws provided in the hardware package. Connections should be made with the screw heads up and the threads pointing down. Element screws should be tightened to 30 inch lbs. Refer to Figure 6 for proper positioning.



WARNING

HAZARDOUS VOLTAGE: Risk of electric shock. Can cause injury or death.

- ◆ **DO NOT** remove the electrical panel cover while system is energized.
- ◆ **Position** elements properly to avoid short circuiting them against metal surfaces.
- ◆ **Protect** element lead wires from front panel screws and any field installed screws to avoid short circuit.

ELEMENT INSTALLATION
FIGURE 6

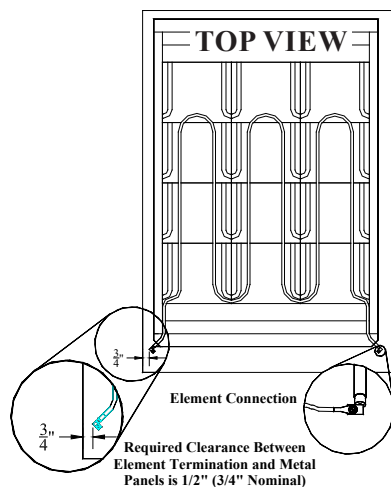

AIR CHANNEL PLACEMENT
FIGURE 7

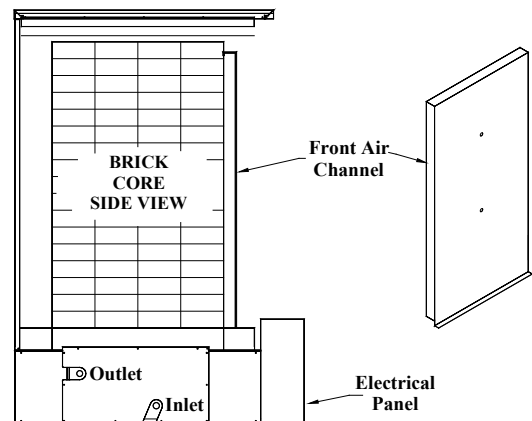

BRICK CORE TEMPERATURE SENSOR INSTALLATION

Step 1 Remove the screw(s) around the brick core temperature sensor hole(s) in the galvanized front panel.

NOTE: Models 5130 and 5140 have an upper and a lower brick core temperature sensor.

Step 2 Insert the brick core temperature sensor(s) through the hole(s) in the galvanized front panel. If installing a system with two sensors, be sure the one marked as the upper sensor is installed in the upper position and the one marked as the lower sensor is installed in the lower position. The sensor(s) must pass through the blanket insulation and into the brick core. Holes have not been pre-drilled through the insulation. Use the sensor(s) to aid in making a passageway by rotating the sensor(s) side-to-side while gently pushing inward.

Step 3 Once the brick core sensor(s) is installed, put the screw(s) back into position in the galvanized front panel to hold the sensor(s) in position and to provide the electrical ground.

Step 4 Check the non-insulated element terminations to make sure they do not come within 1/2" of any surface area on the system.

Step 5 Re-install the painted front panel, using the previously removed screws.

	CAUTION
Risk of improper operation. Proper installation of the brick core temperature sensor(s) is critical to the operation of the Comfort Plus Hydronic heating system. Read and follow installation instructions carefully.	

LINE VOLTAGE ELECTRICAL CONNECTIONS

In standard configuration, the Comfort Plus Hydronic is wired for connection to 240V, however, the element circuits can also be connected to 208V. A 208V connection derates the charging input of the system by 25%. If a system rated specifically for 208V or 277V is required, contact the factory. The controls circuit i MUST be connected to 120V/240V or 120V/208V. If connecting to 120/208V, contact the factory for programming information.

The 60 amp breakers located in the electrical compartment on the Comfort Plus Hydronic feed the core charging (element) circuits. The 15 amp breaker feeds the controls, blowers, and pumps circuit. All Comfort Plus Hydronic systems are factory configured to be field connected to multiple line voltage circuits. If a single feed line voltage circuit is desired, an optional single feed kit is available from the factory.

To determine the correct wire size required for each circuit feeding the Comfort Plus Hydronic, refer to the Specifications (Page A.01) and the system's identification label (Figure 8) located on the lower left side of the Comfort Plus Hydronic system.

Step 1 Route all line voltage wires through a knockout and into the electrical panel of the Comfort Plus Hydronic.

Step 2 Make proper field wiring connections to the Comfort Plus Hydronic breakers. Refer to the Line Voltage Wiring Diagrams (Pages A.05-A.07) for more information on these connections.

	WARNING
HAZARDOUS VOLTAGE: Risk of electric shock. Can cause injury or death.	
<ul style="list-style-type: none">DO NOT energize the system until installation is complete.DO NOT operate the Comfort Plus Hydronic heating system without the factory supplied junction box in place. Connections to the primary loop pump MUST be made inside the junction box. If installing the optional air handler, the air handler pump connections MUST also be made in the junction box.Equipment must be installed by a qualified technician in compliance with all applicable local, state, and national codes and regulations.	

SAMPLE SYSTEM IDENTIFICATION LABEL

FIGURE 8

Manufactured in U.S.A. **STEFFES CORPORATION** **UL** US LISTED 5P99

Model S/N U.S. Patents - 5201024, 5086493

Maximum Working Pressure PSIG Option Canadian Patents - 2059158, 2060881

Maximum Discharge Water Temperature

Connections Required for Multi-Circuit Feed Control Circuit
 Volts Amps Hz Wire

Min Circuit Ampacity Amps
 Max Fuse or Circuit Breaker Size Amps

Charge Circuit #1 Volts Watts
 Charge Circuit #2 Volts Watts
 Charge Circuit #3 Volts Watts
 Charge Circuit #4 Volts Watts

Connections Required for Single Circuit Feed
 Volts Amps Hz Wire
 Min Circuit Ampacity Amps
 Max Fuse or Circuit Breaker Size Amps

Max Amps of Motors and Pumps Connected
 *Primary Pump Amps HP Volts
 *Secondary Pump Amps HP Volts
 Core Blower Amps HP Volts
 *Opt. House Blower Amps HP Volts
 *Opt. Heat Recovery Amps HP Volts
 * May be field installed

Unit Clearance Requirements (5100 series)
 Allow three (3) inches from back and right side of unit and six (6) inches from the top of the unit to combustibles. Allow thirty-six (36) inches front and left side clearance to provide space for servicing. One (1) inch bottom clearance is required to combustibles.

CIRCUIT PHASING CONNECTIONS

FIGURE 9

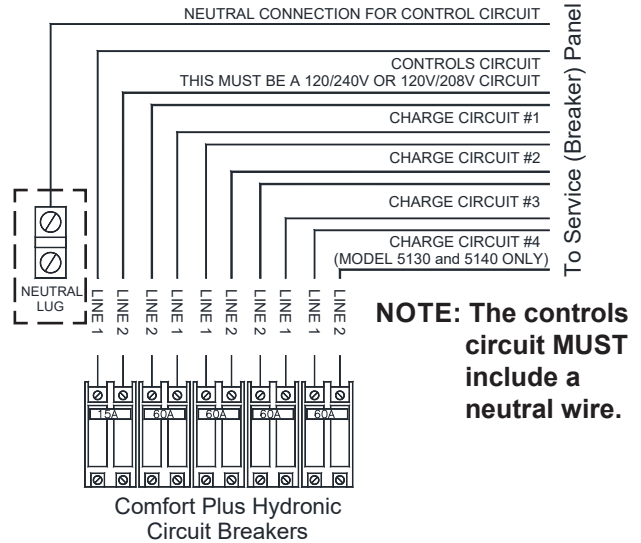

IMPORTANT

- ♦ To ensure proper operation and safety, all line voltage circuits must be segregated from low voltage wiring in the Comfort Plus Hydronic.
- ♦ To reduce electro magnetic fields associated with electrical circuits and to avoid induced voltage on sensors and electronic devices, the circuit phases MUST be alternated as shown in Figure 9.

JUNCTION BOX INSTALLATION

- Step 1** Attach the factory supplied junction box to the left side of the Comfort Plus Hydronic system as shown in Figure 16 (Page 3.12).
- Step 2** Make connections to the primary loop pump and air handler pump inside this junction box. The red and white wires connect to the primary loop pump and the black and white wires connect to the air handler pump. (See Figure 10.) The maximum connected amperage on either of these circuits is 1.2 amps.
- Step 3** Attach the junction box cover using the screws provided.

LINE VOLTAGE WIRING DIAGRAM
FIGURE 10

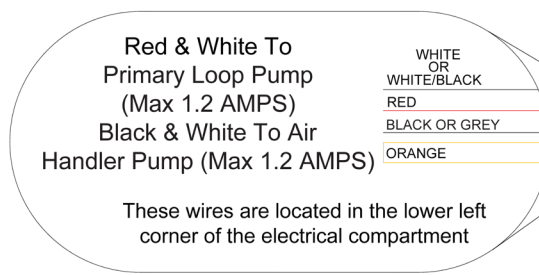

5120 Line Voltage
Wiring Diagram 240/208 Volt
Use copper or aluminum conductors rated at 75°C or higher for field connections of this device.

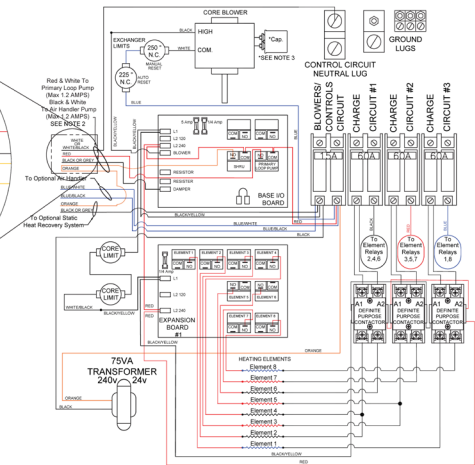

NOTE: If utilizing the optional air handler, the orange wire can be used with the white wire to power a secondary pump for hydronic zones.

LOW VOLTAGE ELECTRICAL CONNECTIONS - PEAK CONTROL

Steffes ETS heating equipment may be controlled by the Power Company via a peak control signal. This signal can be sent to the equipment using a Steffes Power Line Carrier control system, low voltage wiring, a Steffes Time Clock Module, or line voltage control. In applications utilizing automatic charge control, outdoor temperature information is required and can be received via an outdoor sensor or power line carrier control system.

IMPORTANT

Low voltage wires
MUST never enter any
line voltage enclosure.

The Comfort Plus Hydronic system is factory configured for low voltage peak control and is set to charge when the utility peak control switch closes. Refer to the Configuration Menu (Pages 3.14-3.15) for information on configuring the system for the application.

LOW VOLTAGE (HARD WIRED) PEAK CONTROL

If using the low voltage peak control option, the Comfort Plus Hydronic is direct wired to the power company's peak control switch. Field connections from the peak control switch are made to the low voltage terminal block through a low voltage knockout located on the left side of the electrical panel.

Step 1 Route a low voltage circuit from the power company's load control or peak signaling device to the low voltage terminal block inside the electrical compartment of the Comfort Plus Hydronic system through one of its low voltage wire knockouts. A black plastic bushing is provided.

Step 2 Connect the field wiring to positions "RP" and "P". (See Figure 11.)

NOTE: To use Comfort Plus to control other loads, refer to Auxiliary Load Control (Page 3.13).

**PEAK CONTROL TERMINAL CONNECTIONS
FIGURE 11**

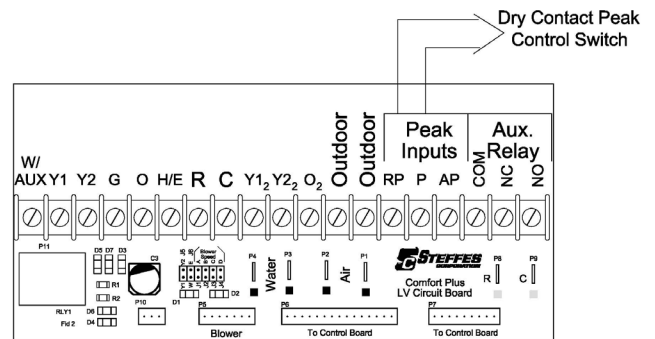

Low Voltage Terminal Block Coding

- RP = Peak Control Input Common
- P = Peak Control Input
- AP = Anticipated Peak (Pre-Peak) Control Input
- COM = Peak Control Output Common
- NC = Peak Control Output (Normally Closed)
- NO = Peak Control Output (Normally Open)

POWER LINE CARRIER (PLC) PEAK CONTROL

The Steffes Power Line Carrier (PLC) control system has the ability to communicate with the Comfort Plus Hydronic system through the existing electrical circuits in the structure. With the power line carrier option, hard wired low voltage connections from the power company's peak signaling switch connect directly to the transmitting device. The switch signals peak control times to the transmitter, the transmitter sends the signals to the Comfort Plus Hydronic system, which receives this information and responds accordingly.

In addition to providing peak control signals, the transmitter also provides outdoor temperature information for automatic charge control, room temperature set back, and anticipated peak utility control signals (if applicable).

The PLC control is optional and must be ordered separately. If utilizing a PLC system, an Owner's and Installer's manual will accompany the transmitting device. Refer to this manual for information on the installation and operation of the power line carrier control system.

TIME CLOCK MODULE PEAK CONTROL

The Steffes Time Clock Module is another option for providing a peak control signal to the Comfort Plus Hydronic. It mounts inside the system's low voltage electrical compartment and interfaces with the relay board via an interface cable. Peak control times must be programmed into the system once the module is installed to enable the time clock feature. Refer to the instructions provided with the Time Clock Module for more information on the installation and operation of this device.

LINE VOLTAGE PEAK CONTROL

Line voltage control is also an option, but is not the preferred method of control as it is usually more complex and expensive. If line voltage control is utilized, the controls circuit must be powered with an uninterrupted circuit. An external switching device, such as a relay panel, is necessary to directly control the heating element charging circuits. If relying on this method of control, the faceplate on the system MUST continuously display a brick core operating mode of "C" (charge) regardless of whether it is an off-peak or on-peak period. Refer to C005 of the Configuration Menu for proper settings. (Reference Pages 3.14-3.15.)

LOW VOLTAGE ELECTRICAL CONNECTIONS - OUTDOOR TEMPERATURE SENSOR (REQUIRED)

- Installation Methods:** A) Hard wired to system to the two "Outdoor" terminals (default)
OR
B) Connected to Power Line Carrier (PLC)

Theory of Operation: The outdoor sensor monitors outdoor temperature and provides this information to the system. The system responds by automatically storing heat in its brick core according to outdoor temperature and the heating requirements.

Location of: The outdoor sensor must be placed in a location where it can accurately sense outdoor temperature and is not affected by direct sunlight or other abnormal temperature conditions.

- Wiring:**
- Route low voltage wire from the outdoor sensor to the electrical compartment through one of the low voltage wire knockouts.
 - Connect to "Outdoor" terminals as shown in Figures 13-14.
 - If the sensor wiring is routed through an external wall, the opening through which the wire is routed MUST be sealed. Failure to do so may affect the accuracy of the outdoor temperature sensor.
 - The outdoor sensor is supplied with a lead length of 40 ft. If a greater wire length is needed, it can be extended to a total of 250 ft.
 - No other loads can be controlled or supplied through this cable. It is for connection of the outdoor sensor ONLY.
 - This low voltage cable MUST not enter any line voltage enclosure.
 - Unshielded Class II (thermostat) wire can be used as extension wire provided it is segregated from any line voltage cabling.

IMPORTANT

If connecting to the Steffes power line carrier (PLC) system, follow the installation instructions in the PLC system's Owner's and Installer's Guide.

IMPORTANT

Outdoor sensor wire MUST NEVER be combined with other control wiring in a multi-conductor cable.

LOW VOLTAGE ELECTRICAL CONNECTIONS - ROOM THERMOSTAT

A low voltage (24VAC) room thermostat is required for room temperature control with the Comfort Plus Hydronic system. Steffes recommends using a digital thermostat. If utilizing a mechanical thermostat, a load resistor may be necessary due to the low current draw (.01 amps) on the heat call input circuit of the Comfort Plus system. Contact the factory for information on thermostats available from Steffes.

**LOW VOLTAGE CONNECTIONS
HYDRONIC HEATING SINGLE ZONE SYSTEM
FIGURE 12**

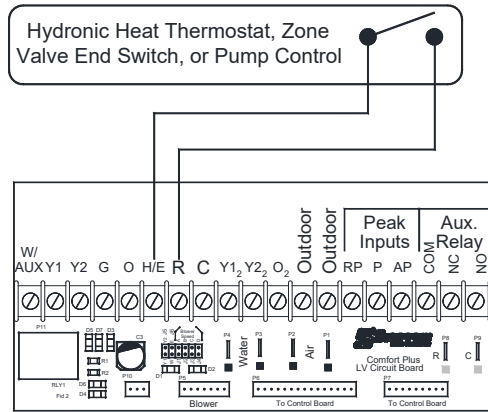

**STANDALONE FURNACE APPLICATION CONNECTIONS SHOWN FOR SINGLE STAGE HEATING / SINGLE STAGE COOLING (UNCONTROLLED AIR CONDITIONING)
FIGURE 13**

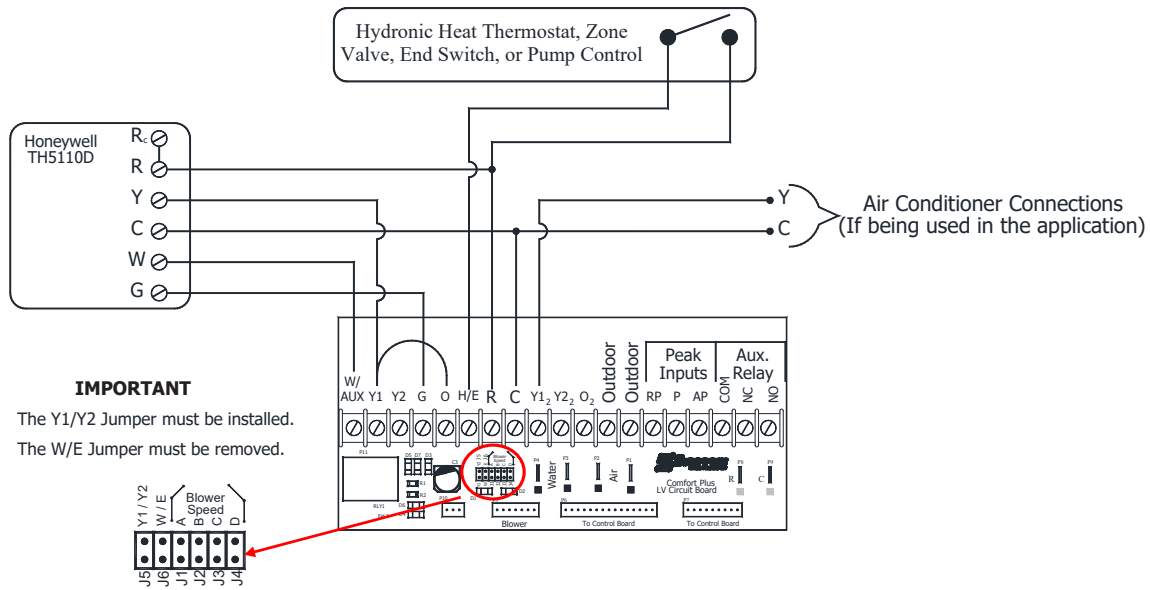

Single Stage Heat / Single Stage Cool **			
Thermostat Stage	Thermostat Output	Heat Call Status on Digital Display*	Discharge Air Temperature Target
Hydronic	Varies	HC3	N/A
1	W	HC2	L049
Fan Only	G	HCF	N/A
Cool	Y/G	COOL	N/A

Contractor Use Only

- * If multiple inputs are active, system will display highest Heat Call values. "COOL" overrides all inputs and stops all heating operations.
- ** Thermostat must be programmed to energize reversing valve for cooling. If outdoor unit used requires the reversing valve be energized for heating, see Configuration Menu on pages 3.14-3.15.

The Comfort Plus Hydronic system can be used in conjunction with an air conditioner or a heat pump. Refer to the optional Air Handler (Page 2.02) and the Low Voltage Connections for Heat Pump Application Diagram (Figures 14-15), for more information on interfacing these systems with the Comfort Plus Hydronic. If multiple heat pumps are being interfaced, contact Steffes.

SINGLE STAGE HEAT PUMP APPLICATION

FIGURE 14

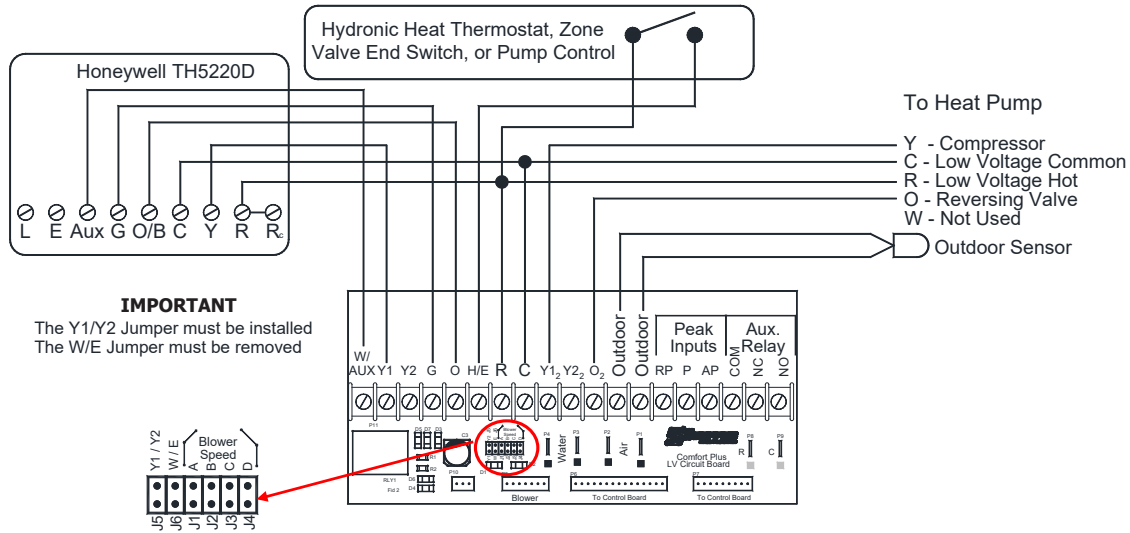

Single Stage Heat Pump with Auxiliary Heat / Single Stage Cool **						
Thermostat Stage	Thermostat Output	Heat Pump Stage	ECM Board Output to Heat Pump*	% of Selected CFM	Heat Call Status on Digital Display*	Discharge Air Temperature Target
1	Y/G	1	R/Y ₁ ₂	100%	HC1	L048/C010
Aux	Aux/Y/G	1	R/Y ₁ ₂	100%	HC2	L049
Fan	G	0	R	400 cfm	HCF	N/A
Cool	Y/G/O	1	R/Y ₁ ₂ /O ₂	100%	COOL	N/A
Hydronic	Varies	N/A	N/A	OFF	HC3	N/A
Contractor Use Only						

* If multiple inputs are active, system will display highest Heat Call values. "COOL" overrides all inputs and stops all heating operations.

** Thermostat must be programmed to energize reversing valve for cooling. If outdoor unit used requires the reversing valve be energized for heating, see Configuration Menu on pages 3.14-3.15.

TWO STAGE HEAT PUMP APPLICATION

FIGURE 15

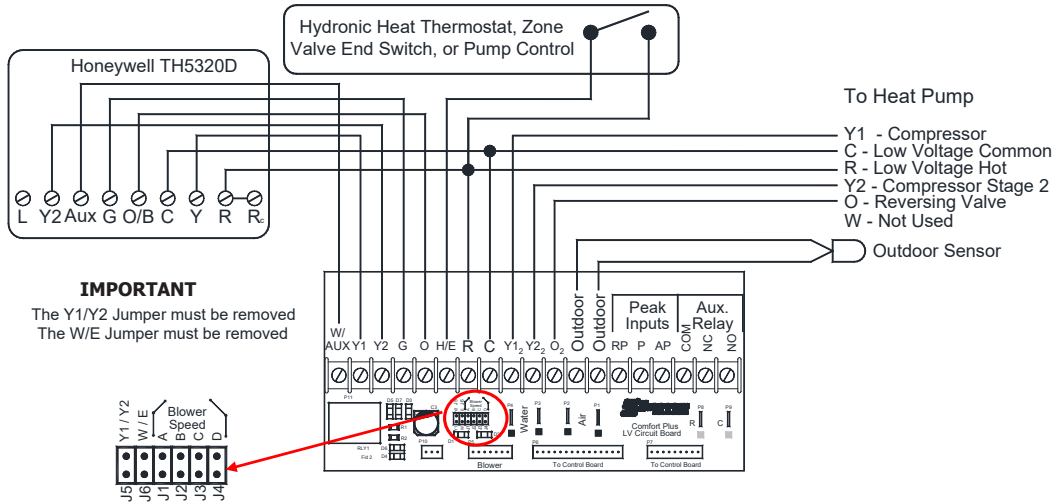

Two Stage Heat Pump with Auxiliary Heat / Two Stage Cool ***						
Thermostat Stage	Thermostat Output	Heat Pump Stage	ECM Board Output to Heat Pump*	% of Selected CFM	Heat Call Status on Digital Display*	Discharge Air Temperature Target
1	Y/G	1	R/Y ₁ ₂	50% or 70%**	HC1	L048/C010
2	Y/Y2/G	2	R/Y ₁ ₂ /Y ₂	100%	HC1	L048/C010
3	Aux/Y/Y2/G	2	R/Y ₁ ₂ /Y ₂	100%	HC2	L049
Fan	G	0	R	400 cfm	HCF	N/A
Cool 1	Y/G/O	1	R/Y ₁ ₂ /O ₂	50% or 70%**	COOL	N/A
Cool 2	Y/Y2/G/O	2	R/Y ₁ ₂ /Y ₂ /O ₂	100%	COOL	N/A
Hydronic	Varies	N/A	N/A	OFF	HC3	N/A
Contractor Use Only						

* If multiple inputs are active, system will display highest Heat Call values. "COOL" overrides all inputs and stops all heating operations.

** Systems built before 1/1/2011 are configured for 50% airflow in Stage 1. For more information, refer to Instruction #1200601-High Speed Stage 1 Relay Installation.

*** Thermostat must be programmed to energize reversing valve for cooling. If outdoor unit used requires the reversing valve be energized for heating, see Configuration Menu on pages 3.14-3.15.

PRESSURE RELIEF VALVE INSTALLATION



WARNING

Risk of explosion. Can cause injury or death. The factory supplied pressure relief valve **MUST** be connected to the system with the supplied fittings.

- ♦ **DO NOT** modify this assembly.
- ♦ **DO NOT** cap, plug, or otherwise obstruct the outlet of the pressure relief valve.
- ♦ **DO** mount the pressure relief valve in a vertical, upright position.
- ♦ This pressure relief valve is sized to service the needs of the **Comfort Plus Hydronic heating system**. If multiple heating systems are being used, pressure relief valving for the other system **MUST** be provided separately.

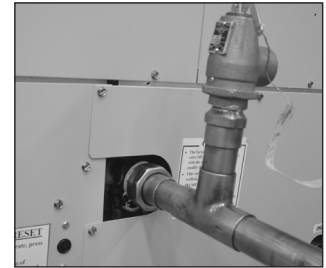

Step 1 Remove the exchanger access panel and locate the pressure relief valve assembly.

Step 2 Connect the pressure relief valve to the outlet water port on the left side of the Comfort Plus Hydronic. It is extremely important that the following conditions for installation of this part are met:

- Ensure all connections, including the valve inlet are clean and free from any foreign material.
- Use pipe compound sparingly, or tape on external threads only.
- Mount the pressure relief valve in a vertical, upright, position directly to the outlet water port of the system. Under no circumstances should there be a flow restriction or valve of any type between the safety relief valve and the pressure vessel.

Step 3 Use schedule 40 pipe to install a discharge line for the pressure relief valve. This discharge line **MUST**:

- be connected from the valve outlet with no intervening valve and directed downward to a safe point of discharge.
- allow complete drainage of both the valve and the discharge line.
- be independently supported and securely anchored to avoid applied stress on the valve.
- be as short and straight as possible.
- terminate freely to atmosphere where any discharge is clearly visible and is at no risk of freezing.
- terminate with a plain end that is not threaded.
- be constructed of a material suitable for exposure to temperatures of 375°F/190°C or greater.
- be, over its entire length, of a pipe size equal to or greater than that of the valve outlet.

Available Pressure Relief Valves	Minimum BTU Rating	Maximum Operating Pressure	Order Item #
30 PSI	400,000	20 PSI	1100104
75 PSI	500,000	60 PSI	1100105
150 PSI	500,000	125 PSI	1100106

Note: 5100 Series Systems are shipped with 30 PSI pressure relief valves. If a different valve is required, order the item number listed.



CAUTION

Risk of discharged hot water and/or steam. Can cause personal injury or property damage. During operation, the pressure relief valve may discharge large amounts of steam and/or hot water. To reduce the potential for bodily injury or property damage, install a discharge line.

PLUMBING

The Comfort Plus Hydronic heating system **MUST** be plumbed with a primary loop and secondary (zone) loops. The primary loop needs to consist of a minimum of 10' of 1" pipe and requires its own pump (circulator). The secondary (zone) loops require additional pump(s) to operate effectively. Refer to Typical Primary Loop (Figure 16) and the Typical System Plumbing Diagrams (Figures 17 and 18) for installation information.

The primary loop serves to regulate heat transfer from the system's heat exchanger. The primary loop pump must be powered by the Comfort Plus Hydronic control system as shown in Figure 17-18.

**TYPICAL PRIMARY LOOP
FIGURE 16**

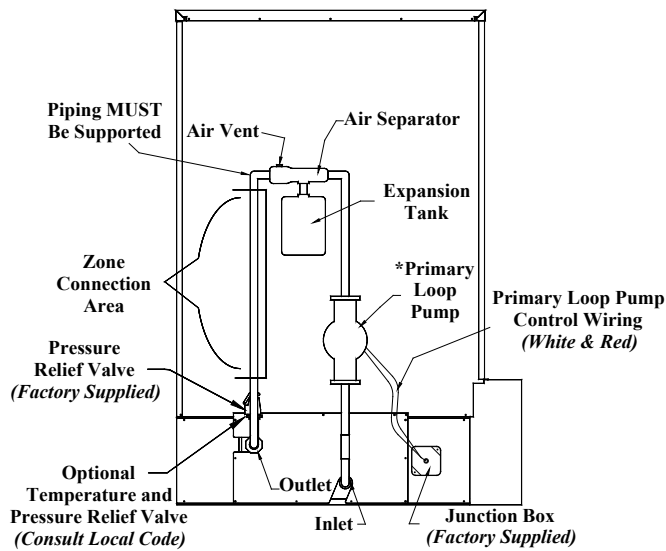

PRESSURE DROP THROUGH HEAT EXCHANGER	
STATIC PRESSURE (Feet Water Column) Based on 80 degree entry water temperature with a 50% glycol mix.	.1 ft @ 2 GPM
	.2 ft @ 4 GPM
	.4 ft @ 6 GPM
	.7 ft @ 8 GPM
	1.1 ft @ 10 GPM

HEAT EXCHANGER SPECIFICATIONS	
Capacity	1.2 Gallons
Maximum Flow	10 GPM
Tubing Material	Copper
Maximum Outlet Water Set Temperature	185°F/85°C

PUMP SPECIFICATIONS

- Steffes recommends a Taco 007 or equivalent single speed 115VAC pump for the primary pump.
- Air Handler pump should NOT be a split phase pump.
- Air Handler pump should NOT have any type of auxiliary control built into or onto the pump.

CAUTION

FREEZE PROTECTION: Risk of frozen pipes. Can cause property damage. Hydronic heating system freeze-ups WILL cause extensive damage to the entire heating system and/or property. It is the responsibility of the installer to provide protection against freezing.

PIPING SUPPORT: Risk of exchanger damage. Can cause property damage or personal injury. DO NOT use the exchanger as support for piping. Support brackets should be in place to ensure proper operation of the system and to keep pressure off the inlet and outlet piping.

**TYPICAL SYSTEM PLUMBING
SINGLE TEMPERATURE ZONES
FIGURE 17**

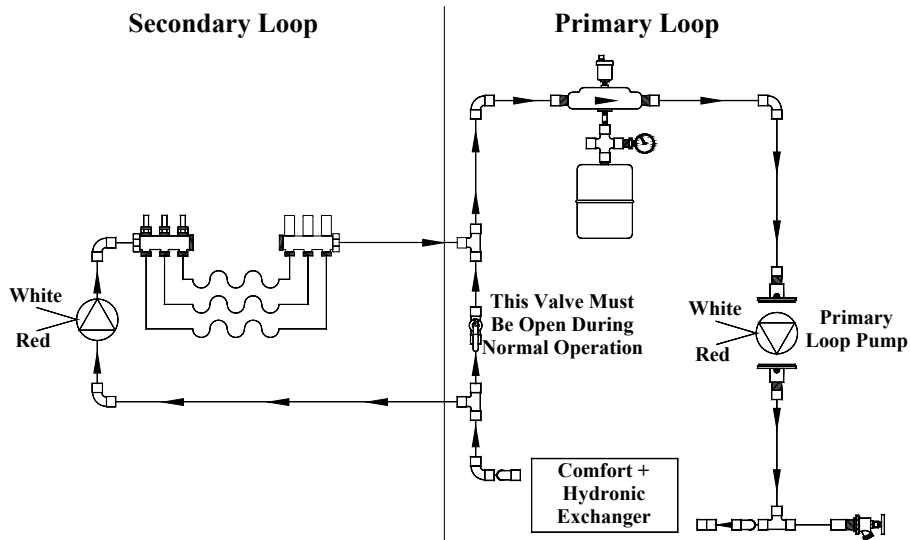

IMPORTANT

It is the responsibility of the installer to prevent involuntary flow of water to the air handler. Not doing so may cause limit tripping and/or decrease heat pump efficiency. Use of a check valve, zone valve, or other device may help prevent involuntary flow.

**TYPICAL SYSTEM PLUMBING
(SHOWN WITH STEFFES AIR HANDLER)**

FIGURE 18

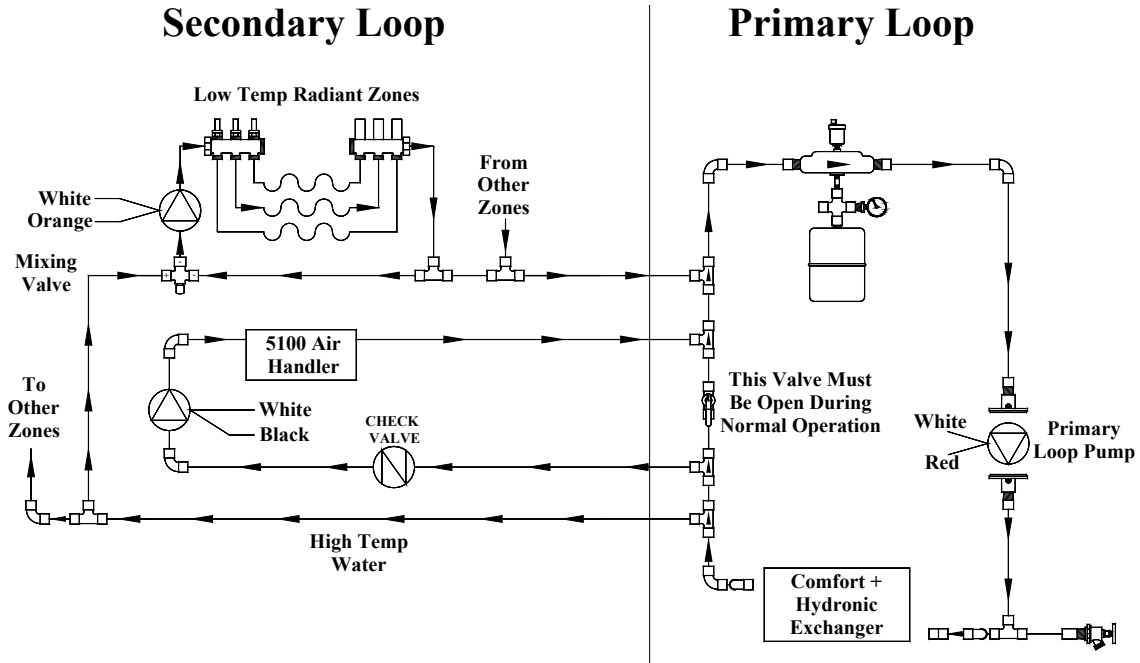

AUXILIARY LOAD CONTROL

The Comfort Plus Hydronic system can be used to provide control signals to other loads in the application. To do so, connect low voltage control wires to the "COM" and "NC" or the "COM" and "NO" positions of the low voltage terminal block in the electrical compartment of the Comfort Plus Hydronic. (See Figure 19.) These contacts are rated for 30 volts, 3 amps maximum.

TYPICAL AUXILIARY LOAD CONTROL

FIGURE 19

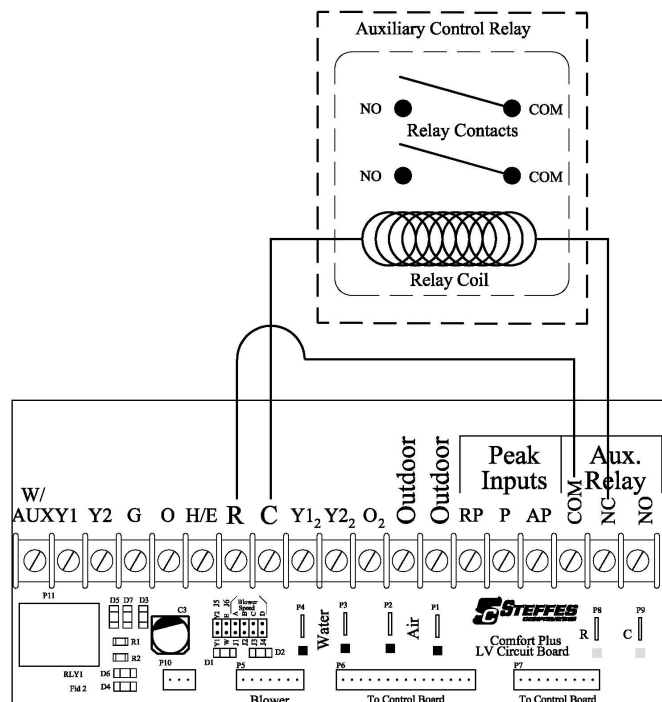

NOTE: During off-peak (charge) periods, the contact is closed between "COM" and "NC".

IMPORTANT

Maximum external load should not exceed 60 VA on the system's class II transformer.

CONFIGURATION MENU

The Steffes Comfort Plus Hydronic heating system has a Configuration Menu, which allows the system to be customized to the power company and consumer's needs. This menu can be accessed on start-up and allows configuration settings to be easily adjusted.

To access the Configuration Menu:

- Step 1** Energize the system. Access to the Configuration Menu is allowed for the first two (2) minutes of operation. If the system has been energized for more than two (2) minutes, the 15 amp circuit breaker must be powered off and back on to gain access to this menu.
- Step 2** Press and release the **M** button until the faceplate displays "CONF".
- Step 3** Press the up arrow once and the faceplate will display "C000". The faceplate will flash between "C000" and the corresponding configuration value.
- Step 4** If necessary, edit the configuration value by pressing and holding the **M** button while using the up or the down arrow button to change the value.
- Step 5** Once the value is correct, release the buttons and press the up arrow button to go to the next configuration (C001, C002, etc.)
- Step 6** Repeat steps 4 through 5 until all configuration settings have been adjusted to the desired values.
- Step 7** Once configured, use the down arrow to leave the Configuration Menu.

IMPORTANT

If access to the Configuration Menu times out, the 15 amp circuit breaker must be powered off and back on to re-enter the menu.

In most applications only a few, if any, configuration changes will be necessary. Following is a description of the configuration settings and their function:

- C000 Off-Peak Method of Charge Control** - Sets the method of brick core charging to be used during off-peak (charge) periods. System is configured for automatic charge control which is a value of five (5).
- C001 Start Brick Core Charge Set Point** - If utilizing automatic charge control as set in C000, this value indicates the outdoor temperature at which the system will start charging.
- C002 Full Brick Core Charge Set Point** - If utilizing automatic charge control as set in C000, this value indicates the outdoor temperature at which the system will target a full core charge.
- C003 Power Line Carrier (PLC) Channel Selection** - If using PLC communication, this setting must match the channel setting in the Steffes PLC transmitting device. A value of zero indicates power line carrier communication is disabled.
- C004 Optional Controls Configuration**
- | <u>Value</u> | <u>Configuration Description</u> |
|--------------|---|
| 8 | No Outdoor Sensor/No Time Clock Module |
| 9 | Outdoor Sensor/No Time Clock Module |
| 12 | No Outdoor Sensor/Time Clock Module (unlocks C013-C021) |
| 13 | Outdoor Sensor/Time Clock Module (unlocks C013-C021) |
- C005 Control Switch Configuration** - If utilizing power line carrier control, the Steffes Time Clock Module, line voltage peak control, or if the utility control switch opens for charging this value should be zero (0). For all other applications, this value should be one (1).

Configuration Menu continued on next page...

C006 Output Control Configuration - Configures the output controls of the Comfort Plus Hydronic system. To determine the value, check the options desired from the list below. Then, add the numbers from the “**Value**” column and enter the sum into this location. If not used in conjunction with a heat pump or air conditioner, the value in this location should be set to two (2).

<u>Value</u>	<u>Option Selected</u>
2	All Comfort Plus Hydronic Systems (5100 Series)
8	Enables compressor control if there is a "COOL" call during a peak (control) time.
32	If a peak (control) period and a cooling call, the compressor will turn off and on in 20 minute intervals (off 20 minutes, on 20 minutes, off 20 minutes, etc.).
128	Interfaces Comfort Plus Hydronic with a heat pump that has a reversing valve which is energized for heating.

C007 Charge Factor - This configuration should be set to a value of 30.

NOTE: *C008 through C009 configurations are only applicable if the Comfort Plus Hydronic system is being used in conjunction with a heat pump.*

C008 Heat Pump Compressor Outdoor Lock-Out Temperature for Off-Peak or Anticipated Peak Modes - Indicates the outdoor temperature at which the heat pump’s compressor is locked out and not allowed to operate during an off-peak or anticipated peak period.

C009 Heat Pump Compressor Outdoor Lock-Out Temperature for On-Peak Mode - Indicates the outdoor temperature at which the heat pump’s compressor is locked out and not allowed to operate during an on-peak period.

C010 Minimum Discharge Air Temperature - Sets the minimum discharge air temperature the system targets during a Stage 1 heat call if using an air handler.

NOTE: *C011 and C012 configurations must be set for the hottest temperature zone in the installation. C011 is the highest temperature the system will target and C012 is the lowest temperature the system will target during a heat call. Outdoor reset is done using these two temperatures. (See graph.)*

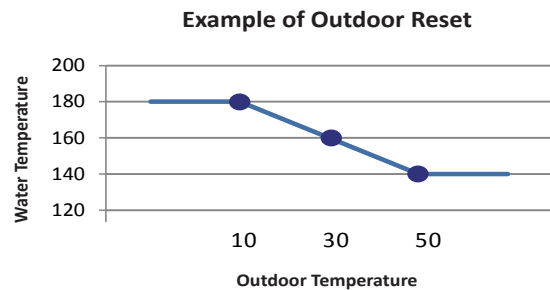

C011 Maximum Outlet Water Temperature - The value set indicates the maximum outlet water temperature to be targeted. The targeted outlet water temperature is affected by the values in C001 and C002. For example, if the value in C001 = 50; C002 = 10; C011 = 180; C012 = 140, then at an outdoor temperature of 30 degrees, the targeted outlet water temperature would be 160 degrees.

C012 Minimum Outlet Water Temperature - The value set indicates the minimum outlet water temperature to be targeted. The targeted outlet water temperature is affected by the values in C001 and C002. For example, if the value in C001 = 50; C002 = 10; C011 = 180; C012 = 140, then at an outdoor temperature of 30 degrees, the targeted outlet water temperature would be 160 degrees.



CAUTION

Risk of high temperature water. Can cause property damage. Improper water temperature settings can result in damage to the floor covering. Make sure the maximum and minimum water temperatures are appropriate for the application.

C013-C021 Time Clock Module Configuration - These configuration settings are used to configure the peak control times when utilizing the optional Steffes Time Clock Module. Refer to the installation and configuration instructions included with the module for more information.

NOTE: *208V SYSTEMS ONLY: In standard configuration, Steffes heaters are dual rated for 240V and 208V power connections. The heaters are factory configured for 240V. If the control circuit is operating on 208V power, the value in Location 28 (L028) must be changed to 5.*

INSTALLER'S FINAL CHECK-OUT PROCEDURE

**WARNING**

HAZARDOUS VOLTAGE:
Risk of electric shock.
Can cause injury or death.
System may be connected
to more than one branch
circuit. Disconnect power
to all circuits before ser-
vicing. Equipment must
be serviced by a qualified
technician.

Step 1 Verify that the water pressure is correct for the application. The water pressure of the Comfort Plus Hydronic heating system should be between 12 and 20 psig.

Step 2 Verify that the operating mode displayed on the control panel corresponds with the power company's peak control signal. Refer to the Operating Status section (Page 1.02) for more information on the proper operating mode.



Step 3 Press the up arrow one time and verify that the outdoor temperature information displayed on the control panel is approximately the same as the current outdoor temperature. Refer to the Operating Status section (Page 1.02) for more information on the outdoor temperature display.

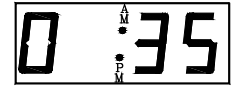

Step 4 Press the up arrow again and the current heat call status will be displayed on the control panel. Refer to the Operating Status section (Page 1.02) for more information on the heat call status display.



Step 5 Initiate a heat call from each room thermostat (one at a time) and verify that the Comfort Plus Hydronic system recognizes the appropriate heat call. Refer to the Operating Status section (Page 1.02) for information on the various heat call status displays. In applications utilizing the Air Handler, verify that the Air Handler and/or heat pump operates appropriately.

Step 6 If utilizing the Air Handler, initiate a cooling call from the room thermostat and verify that the Comfort Plus Hydronic system recognizes the "COOL" call. Verify that the Air Handler, heat pump, and/or air conditioner operates appropriately.

Step 7 Press the up arrow until the targeted brick core charge level is displayed on the control panel. With the system in an off-peak (charge) mode, initiate the charge control override. Refer to the Charge Control Override section (Page 1.03) for instructions on initiating the charge control override. Once initiated, the target level of the Comfort Plus Hydronic should be 100 percent, the control panel should display "tL: F", and all of the heating elements should be energized.



Step 8 With an amp meter, verify that the amperage of the system is correct for the installation. Refer to the System Identification Label on the Comfort Plus Hydronic system for information regarding the proper amperage.

Step 9 Cancel the charge control override and verify that all elements in the system de-energize. Refer to the Charge Control Override section (Page 1.03) for instructions on canceling the charge control override.

Step 10 Verify that all hydronic heating zones are operating as intended.

Step 11 Verify, once again, that the "Operating Mode" displayed on the control panel corresponds with the power company's peak control signal.

Step 12 In applications utilizing the Steffes Power Line Carrier control system, complete the Installer's Final Check-out Procedure in the Owner's and Installer's Manual provided with that device.

Step 13 Complete the manufacturer's warranty card and return promptly.



Appendix

Specifications

Model	5120			5130		5140	
Charging Input (See Note 1)	14.0 kW	19.2 kW	24.8 kW	28.8 kW	37.2 kW	38.4 kW	45.6 kW
Single Feed: Minimum Circuit Ampacity 240 V (Includes 25% Derate for Continuous Load)	84 AMPS	110 AMPS	140 AMPS	160 AMPS	204 AMPS	210 AMPS	248 AMPS
Element Current Draw	59 AMPS	80 AMPS	104 AMPS	120 AMPS	155 AMPS	160 AMPS	190 AMPS
Element Circuits Required (See Note 2)	1-20 AMP 2-30 AMP	1-30 AMP 2-40 AMP	1-40 AMP 2-50 AMP	4-40 AMP	4-50 AMP	4-50 AMP	4-60 AMP
Pump and Blowers/Controls Circuit Required	1-15 AMP (10 AMPS maximum load)						
Pump Voltage	120V (Neutral Conductor Required)						
Blower/Controls Voltage	240V or 208V						
System Dimensions (W x D x H in inches)	29 x 46.5 x 46			29 x 46.5 x 57		29 x 46.5 x 68	
Storage Capacity (See Note 3)	120 kWh (409,440 BTU)			180 kWh (614,160 BTU)		240 kWh (818,880 BTU)	
Approximate Installed Weight (See Note 4)	2,218 lbs			3,046 lb		3,894 lbs	
Number of Brick Whole Brick Half Brick	105 6			150 12		198 12	
Pipe Size- Water Inlet/Water Outlet	1"						
Output Water Temperature Selection Range	50°F/10°C to 185°F/85°C						
Maximum Working Pressure	20 PSIG requires 30 PSI Pressure Relief Valve (Standard) Optional: 60 PSIG req. 75 PSI Pressure Relief Valve; 125 PSIG req. 150 PSI Pressure Relief Valve						
Minimum Flow Rate (primary loop)	1 GPM per 10,000 BTU of required output at 20°F temperature rise (10 GPM maximum)						
Maximum Maintainable Heat Loss (See Note 3)	20,414	27,996	34,175	41,994	49,212	55,992	65,615
8 Consecutive Charge Hours (BTU/hr)	30,621	41,994	45,566	62,991	65,615	83,988	87,487
12 Consecutive Charge Hours (BTU/hr)	30,621	41,994	54,242	62,991	81,363	83,988	99,738
6/4/6/8 Charge Strategy (BTU/hr)							
Internal Pressure Drop (assuming 50% glycol mix)	.1 ft @ 2 GPM .2 ft @ 4 GPM		.4 ft @ 6 GPM .7 ft @ 8 GPM			1.1 ft @ 10 GPM	

Note 1: Standard configuration (240V) systems can be connected to 208V; however, the charging input of the system will derate by 25%. If 208V specific charging voltage is required, it is available as a special factory order. For 277V systems, refer to the 7100 series.

Note 2: Unit is factory configured with multiple line voltage, single phase circuit connections. If single feed to the element and blowers controls circuits is desired, an optional single feed kit is available. Phase balancing is recommended when making connections in 3-phase applications.

Note 3: The size and heating ability of the system required for an installation is dependent on the heat loss of the area and the power company's off-peak hours. In addition, if the unit is not installed within the heated area, heat lost statically must be taken into account when sizing a system. Contact Steffes for assistance in selecting an appropriately sized system.

Note 4: Contact a building contractor or architect if you have structural weight concerns of the installation surface selected. Adhere to all national and local electrical and building code placement requirements for electrical heating appliances.

PARTS DIAGRAM

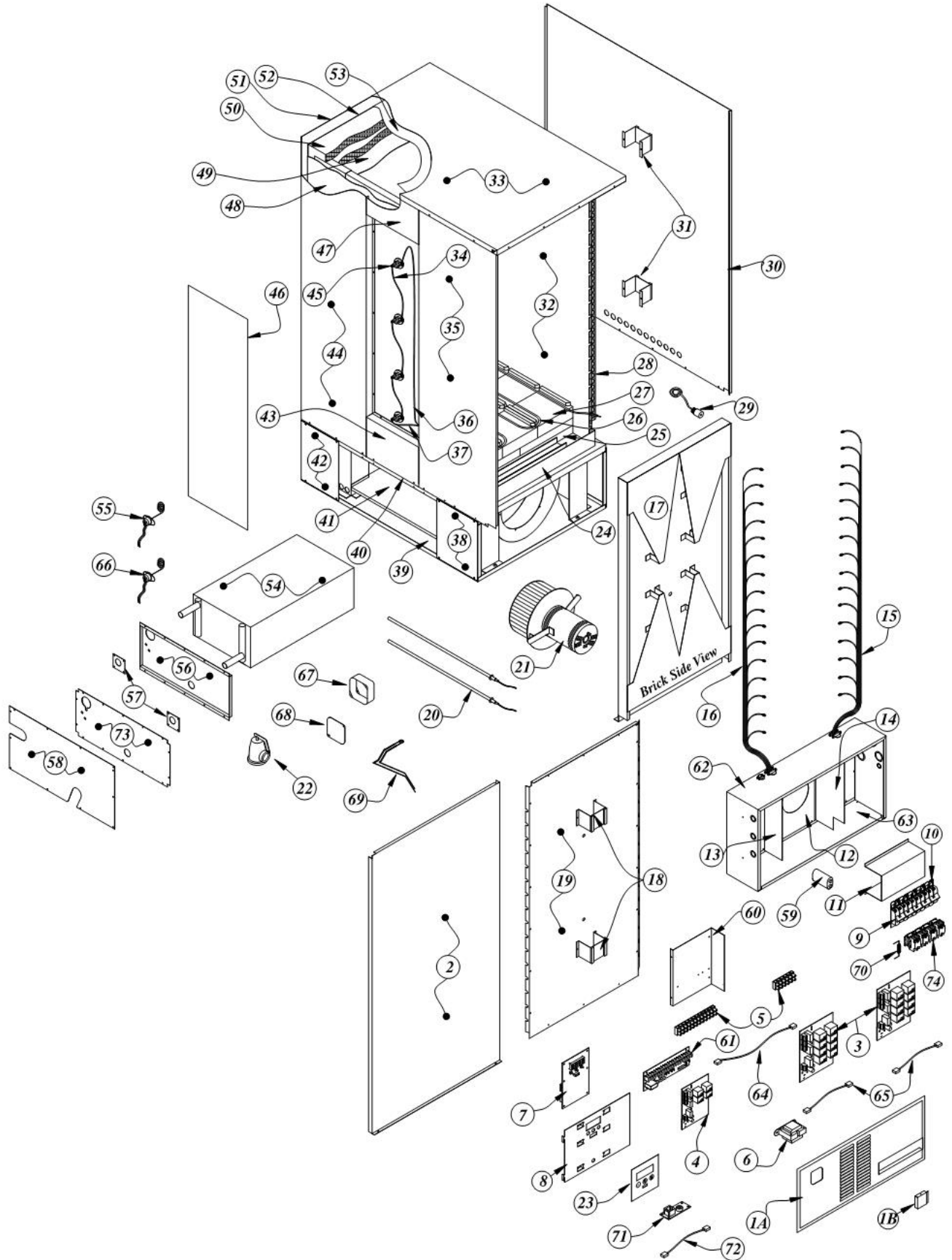

PARTS LIST

NOTE: When ordering parts, please include the system model and serial number.

DWG. REF. NO.	DESCRIPTION	5120 ITEM NO.	5130 ITEM NO.	5140 ITEM NO.
1A	Electrical Panel Cover (non-recessed breakers)	5940853	5940852	5940852
"	Electrical Panel Cover (recessed breakers)	5940845	5940845	5940845
"	Electrical Panel Cover (definite purpose contactor)	5940009	5940009	5940009
1B	Filler, Painted Electrical Panel Cover	5940846	N/A	N/A
2	Front Painted Panel	5940589	5940526	5940588
3	PCB Relay Expansion Board	1023067R	1023067R	1023067R
4	PCB Base I/O Relay Board	1023078R	1023078R	1023078R
5	Terminal Block 12 Position	1016040	1016040	1016040
"	Terminal Block 6 Position	1016041	1016041	1016041
6	Transformer 75VA	1017039	1017039	1017039
7	PCB Processor Control Board	1023065R	1023065R	1023065R
8	Processor Control Board Mounting Bracket	5940850	5940850	5940850
9	Breaker 15 Amp	1024000R	1024000R	1024000R
10	Breaker 60 Amp	1024002R	1024002R	1024002R
11	Breaker Standoff	5940013	5940013	5940013
12	Electrical Panel Insert Center	5940862	5940862	5940862
13	Electrical Panel Insert Left	5940864	5940864	5940864
14	Electrical Panel Insert Right	5940011	5940011	5940011
15	Harness, Breaker to Element Black	1041503	1041515	1041502
16	Harness, Relay to Element Red	1041701	1041713	1041700
17	Front Air Channel	5940824	5940822	5940820
18	Front Standoff	5940513	5940513	5940513
19	Front Galvanized Panel	5940579	5940524	5940578
20	Upper Brick Core Temperature Sensor	N/A	1041725R	1041725R
"	Lower Brick Core Temperature Sensor	1041725R	1041725R	1041725R
21	Core Blower Assembly	1041730R	1041730R	1041730R
"	*Motor Genteq	1020010R	1020010R	1020010R
"	*Motor P-Tech	1040403R	1040403R	1040403R
"	*Wheel Aluminum	1020003R	1020003R	1020003R
22	Pressure Relief Valve	1100104	1100104	1100104
23	Faceplate Label	1159029	1159029	1159029
24	Brick Tray	5940548	5940548	5940548
25	Insulation Block TR19	1052007	1052007	1052007
26	**Heating Elements 2400W 240V	1014021	1014021	1014021
"	**Heating Elements 2850W 240V	N/A	N/A	1014250
"	**Heating Elements 3100W 240V	1014024	1014024	N/A
27	Brick, Boxed	5903025	5903025	5903025
28	Right Side Core	5940559	5940557	5940558
29	Outdoor Sensor - Knockout Style	1302044	1302044	1302044
30	Right Side Painted Panel	5940587	5940525	5940586
31	Right Side Standoff	5940570	5940570	5940570
32	Micropore Insulation Panel	1050142	1050141	1050140
33	Top Painted Panel	5940590	5940590	5940590

* If system was built prior to 2007, the Core Blower Assembly must be ordered.

** Optional voltages available. Contact dealer/distributor with model and serial number to order.

PARTS LIST - CONTINUED

NOTE: When ordering parts, please include the system model and serial number.

DWG. REF. NO.	DESCRIPTION	5120 ITEM NO.	5130 ITEM NO.	5140 ITEM NO.
34	Core Limit Jumper	1041710	1041710	1041710
35	Left Side Front Painted Panel	5940597	5940529	5940596
36	Limit Harness Top	1041504	1041505	1041505
37	Limit Harness Bottom	1041504	1041504	1041504
38	Left Side Front Base Panel	5940881	5940881	5940881
39	Bottom Panel	5940568	5940568	5940568
40	Base Top Panel	5940848	5940848	5940848
41	Bottom Exchanger Tray Panel	5940802	5940802	5940802
42	Back Bottom Base Painted Panel	5940884	5940884	5940884
43	Left Side Bottom Painted Panel	5940594	5940594	5940594
44	Left Side Back Painted Panel	5940599	5940530	5940598
45	Core Limit Switch 290D	1012019	1012019	1012019
46	Limit Zone Painted Cover	5940585	5940527	5940591
47	Left Side Top Painted Panel	5940584	5940584	5940584
48	Left Side Core Panel	5940561	5940565	5940560
49	Insulation Blanket Inner	1054130	1054134	1054140
50	Insulation Blanket Outer	1054132	1054136	1054142
51	Back Painted Panel	5940593	5940528	5940592
52	Galvanized Core Panel Back	5940563	5940567	5940562
53	Galvanized Core Panel Top	5940564	5940564	5940564
54	Exchanger	1100100R	1100100R	1100100R
55	Limit Switch 250D Manual Reset (upper)	1041758R	1041758R	1041758R
56	Left Side Exchanger Panel, Inner	5940814	5940814	5940814
57	Exchanger Access Tube Cover	5940858	5940858	5940858
58	Exchanger Access Painted Panel	Contact Factory	Contact Factory	Contact Factory
59	Core Blower Capacitor Genteq 4 mfd	1018007	1018007	1018007
"	Core Blower Capacitor P-Tech 3 mfd	1018071	1018071	1018071
60	Low Voltage Panel Assembly	1041721	1041721	1041721
61	PCB ECM Motor Interface Var S	1023082	1023082	1023082
62	Electrical Panel, Main Body	5940017	5940017	5940017
63	Electrical Panel, Bottom	5940854	5940854	5940854
64	Cable, Control Board Interface 18"	1010014R	1010014R	1010014R
65	Cable, Expansion Board Interface 12"	1010012R	1010012R	1010012R
66	Limit Switch 225D Auto (lower)	1041756R	1041756R	1041756R
67	Junction Box for Pump Connections	1015100	1015100	1015100
68	Junction Box Cover	1015002	1015002	1015002
69	Outlet Water Sensor	1041748	1041748	1041748
70	Resistor, 1200 ohm	1041764	1041764	1041764
71	Time Clock Module, Optional	1301014	1301014	1301014
72	Cable, Time Clock Module Interface 18"	1010014R	1010014R	1010014R
73	Left Side Exchanger Panel, Outer	5940836	5940836	5940836
74	Definite Purpose Contactor	1018057R	1018057R	1018057R

INTERNAL SYSTEM WIRING DIAGRAMS - LINE VOLTAGE

Line Voltage Wiring Diagram - Model 5120

240V OR 208V SYSTEMS ONLY

NOTE: Use copper or aluminum conductors rated for 75°C or higher for field connection of this device.

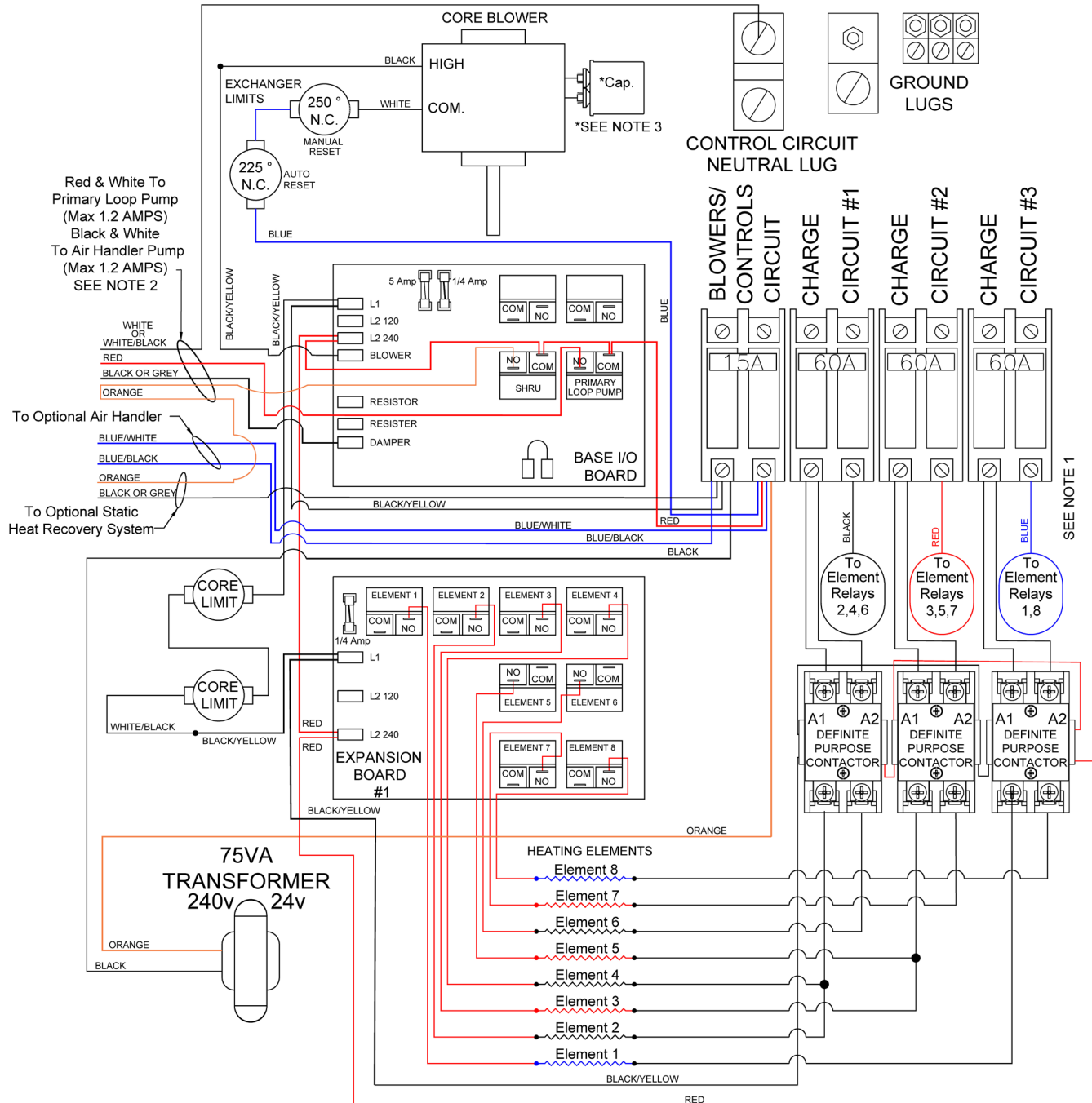

NOTE 1: Line Voltage Field Wiring Connections. See Figure 9 for information on proper circuit phasing.

NOTE 2: For more information regarding pump (circulator) wiring, reference Figures 10, 16 and 17 in the Installation section of this manual.

NOTE 3: The capacitor used will vary depending on which motor is installed. Installing the incorrect capacitor can cause improper speed control function.

INTERNAL SYSTEM WIRING DIAGRAMS - LINE VOLTAGE

Line Voltage Wiring Diagram - Model 5130

240V OR 208V SYSTEMS ONLY

NOTE: Use copper or aluminum conductors rated for 75°C or higher for field connection of this device.

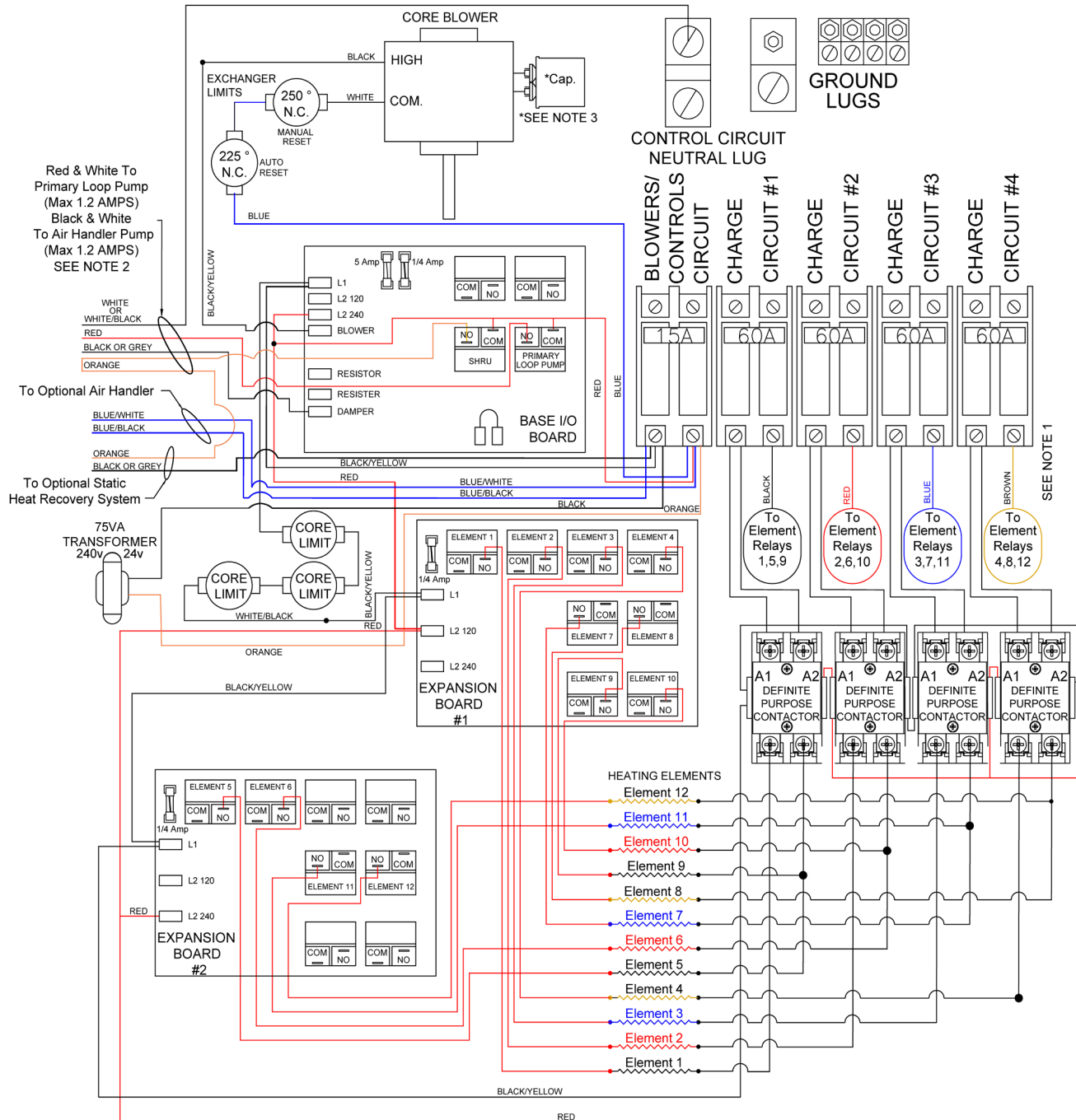

NOTE 1: Line Voltage Field Wiring Connections. See Figure 9 for information on proper circuit phasing.

NOTE 2: For more information regarding pump (circulator) wiring, reference Figures 10, 16 and 17 in the Installation section of this manual.

NOTE 3: The capacitor used will vary depending on which motor is installed. Installing the incorrect capacitor can cause improper speed control function.

INTERNAL SYSTEM WIRING DIAGRAMS - LINE VOLTAGE

Line Voltage Wiring Diagram - Model 5140

240V OR 208V SYSTEMS ONLY

NOTE: Use copper or aluminum conductors rated for 75°C or higher for field connection of this device.

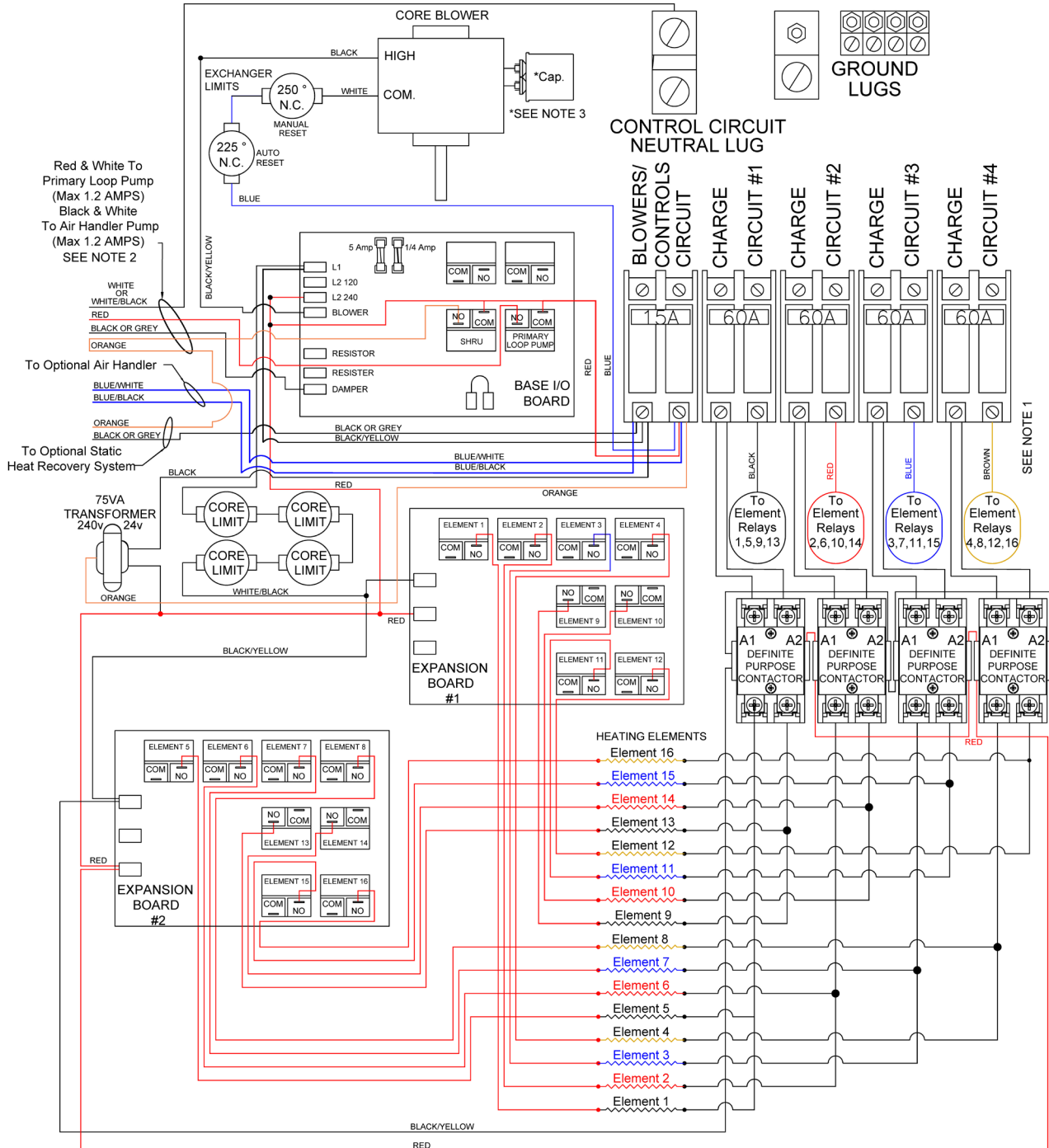

NOTE 1: Line Voltage Field Wiring Connections. See Figure 9 for information on proper circuit phasing.

NOTE 2: For more information regarding pump (circulator) wiring, reference Figures 10, 16 and 17 in the Installation section of this manual.

NOTE 3: The capacitor used will vary depending on which motor is installed. Installing the incorrect capacitor can cause improper speed control function.

INTERNAL SYSTEM WIRING DIAGRAM - LOW VOLTAGE

The outdoor temperature sensor, room thermostat, and peak control device are connected via low voltage wiring.

System Low Voltage Wiring Diagram - Variable Speed Ready

- NOTES:**
- The "R" and "C" positions in the low voltage terminal strip may be used as a source of 24 VAC for powering external low voltage devices (60 VA maximum).
 - Thermostat connections are Class 2 wiring.



WARNING

HAZARDOUS VOLTAGE: Risk of electric shock. Can cause injury or death. All low voltage wiring must be segregated from line voltage circuits in the system.

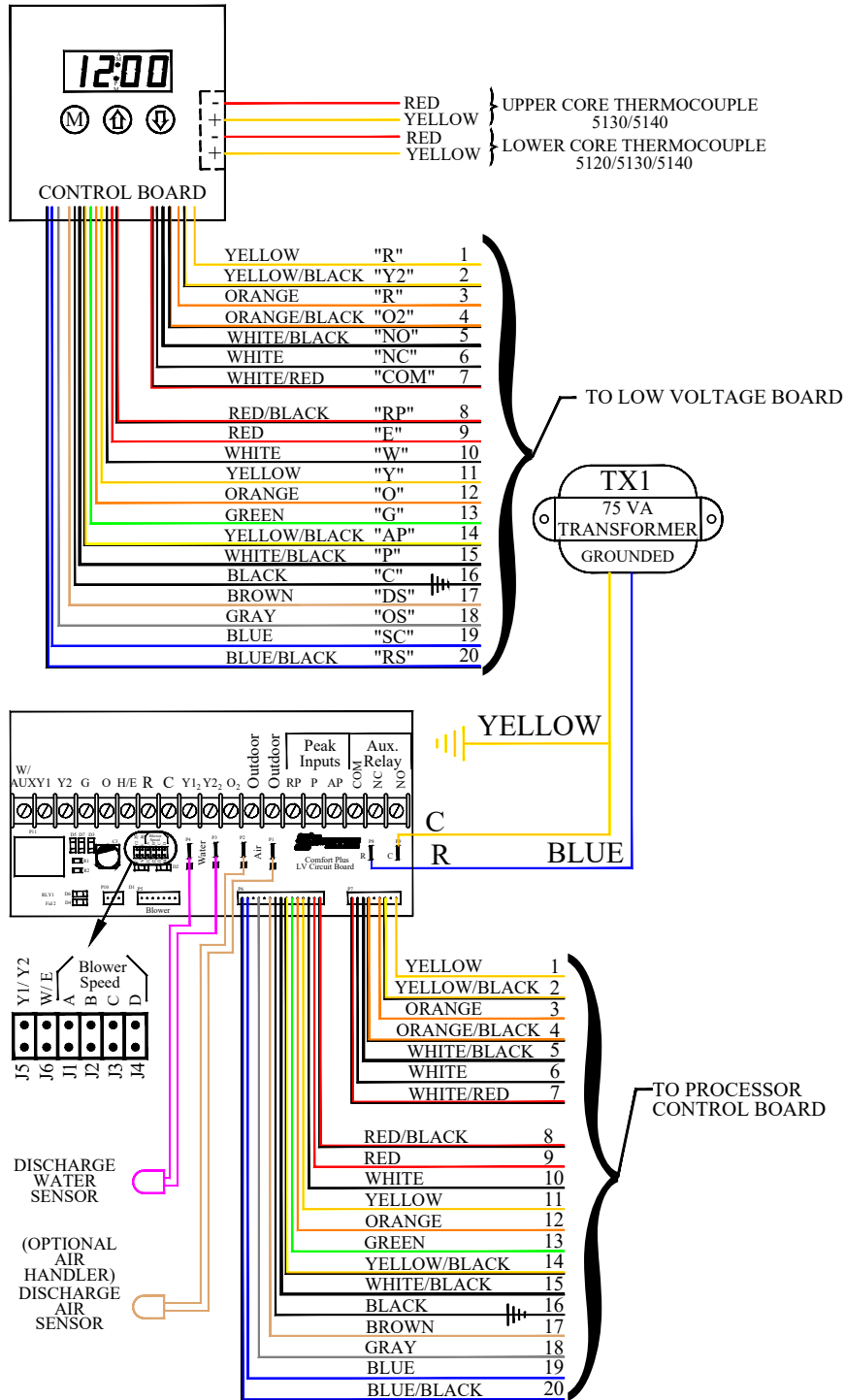

HELP MENU

The Comfort Plus Hydronic system contains a "HELP" menu which may be accessed through the control panel. To access the "HELP" menu, press and release the **M** button until the faceplate displays "HELP". Scroll through this menu by pressing either the up or the down arrow button.

Display

<u>Reading</u>	<u>Description</u>
Fxxx	Firmware Version Number - Indicates the version of software installed.
O xx	Outdoor Temperature - Indicates current outdoor temperature as recognized by the system.
tL:xx	Target Level - Indicates the percentage of brick core charge level the system is targeting. During peak periods the value displays as "tL_".
CL:xx	Charge Level - Indicates the percentage of heat storage currently in the brick core.
HE x	Heating Elements Active - Indicates the total number of heating elements currently energized.
PC x	Power Line Carrier Channel - Indicates the channel on which the system is set to receive PLC communication signal.
P x	Power Line Carrier Net Hit Rate Percentage - Indicates the percentage of "GOOD" communication packets received by the system from the PLC transmitting device.
PS x	Indicates which Specialty Timer the system is currently using. The value displayed will be zero if the Specialty Timer is not being utilized.
CC_x	Charge Mode Operation - Indicates the charge control method being utilized during off-peak periods.
CA_x	A-Peak Mode Operation - Indicates the charge control method being utilized during anticipated peak periods.
C1_x	Specialty Timer #1 Charge Mode - Specialty Applications Only
C2_x	Specialty Timer #2 Charge Mode - Specialty Applications Only
HUxx	Heat Usage - Indicates the percentage of input being dissipated by the system.
A_xx	Target Discharge Air Temperature - Indicates the discharge air temperature that the system is targeting.
cxxx	Compressor Output Relay Delay Timer - Indicates time remaining before heat pump compressor is energized. "c ON" indicates the heat pump is energized.

ERROR CODES

The Comfort Plus Hydronic system has an on-board diagnostic system to monitor various operating conditions. If operating conditions move outside the normal operating range, an error code is displayed on the faceplate. If there are multiple errors simultaneously, only the highest priority error code appears. Once corrected, the next highest priority code will be displayed. Error codes will be displayed on the faceplate as "Er—" (i.e., Er05).

<u>Error Code</u>	<u>Description</u>
01	The lower core (Core A) thermocouple temperature is out of normal operating range. This can be caused by an open, shorted, or otherwise defective thermocouple or a circuit board which is out of calibration.
02	The upper core (Core B) thermocouple temperature is out of normal operating range. This can be caused by an open, shorted, or otherwise defective thermocouple or a circuit board which is out of calibration.



<u>Error Code</u>	<u>Description</u>
03	Outlet water temperature is out of normal operating range. This can indicate an open sensor, a short in the wiring, or a circuit board which is out of calibration.
04	Discharge air temperature is out of normal operating range. This can indicate an open sensor, a short in the wiring, or a circuit board which is out of calibration.
05	Outdoor sensor (direct wired) temperature reading is out of normal operating range. The sensor circuit may be open or shorted, the processor control board may be out of calibration, or there may be an incorrect value in L035.
06	Outdoor sensor temperature from the transmitting device (PLC system) is out of normal operating range. Check the outdoor sensor attached to the transmitting device and the transmitter for proper operation.
07	Main processor control board temperature sensor is out of normal operating range. Verify that none of the clearances have been violated and inspect the condition of the processor control board.
08	Currently not utilized.
09	Currently not utilized.
10	Discharge air temperature has exceeded maximum operating temperature.
20	There is no communication occurring between the Base I/O board and the processor control board. This can be caused by a defective board interface cable or an unresponsive Base I/O board.
21	There is no communication occurring with the first relay expansion board. The board interface cable may be defective or the first expansion board may be unresponsive.
22	There is no communication occurring with the second relay expansion board. The board interface cable may be defective or the second expansion board may be unresponsive.
23	There is no communication occurring with the Steffes time clock module.
24	Temperature sensor offset/reference is out of range and indicates one of the sensors is shorted to ground, the processor control board is out of calibration, or the blower/control circuit is connected to an improper input voltage.
25	Power line carrier system is active; however, no good data has been received.
26	Insufficient main control board memory. Contact a qualified service technician.
27	Insufficient permanent memory. Contact a qualified service technician.
28	Permanent memory change has been made. Press the M button to accept. This error message indicates a change has been made to the software program; therefore, it is important to verify that all location settings are correct for the application.
29	On-board communication system is not fully operable. Contact a qualified service technician.
30	Base I/O control board is in test mode. Check the jumper configuration.
31	Relay expansion board(s) are in test mode. Check the jumper configuration.
39	Indicates the value in Configuration 2 (C002) has been set to a value greater than the value in Configuration 1 (C001). The system will not charge until the value in C002 is set lower than C001.
40	Press and release the M button to clear the error. If the error code reappears, contact a qualified service technician.
41-44	Contact a qualified service technician.
Cold Core	Temperature of the brick core is below 40 degrees or the core sensing thermocouple may be open.
Core Fail	Core high limit switch may be open.
PLC Fail	The system is configured for power line carrier control; however, is not receiving a valid power line carrier communication signal.

DISASSEMBLING THE COMFORT PLUS HYDRONIC SYSTEM

- Step 1** Remove the painted front panel of the brick storage cabinet by removing the sheet metal screws along the top, bottom, and sides of the panel. Detach by pulling the bottom of the panel forward and down.
- Step 2** Remove the limit zone cover by removing the screws holding it in place.
- Step 3** Remove the screws around the perimeter of the limit zone and around the bottom of the left side, right side, and back upper panels. Disconnect limit wiring. Do not remove the limit switches.
- Step 4** Remove the one or two screws in the center of the upper right side panel.
- Step 5** From the back of the system, lift and remove the painted panels. (See Figure A.)
- Step 6** Locate the brick core temperature sensor(s) behind the front panel and disconnect them from their shipping position. Carefully lay the sensor(s) aside to avoid damaging them.
- Step 7** Carefully rock the brick core (Figure B) to one side and lift top portion up and off the base (Figure C.)
- Step 8** Move the Comfort Plus Hydronic heating system into the desired location, reassemble, and continue with the installation instructions in this manual.

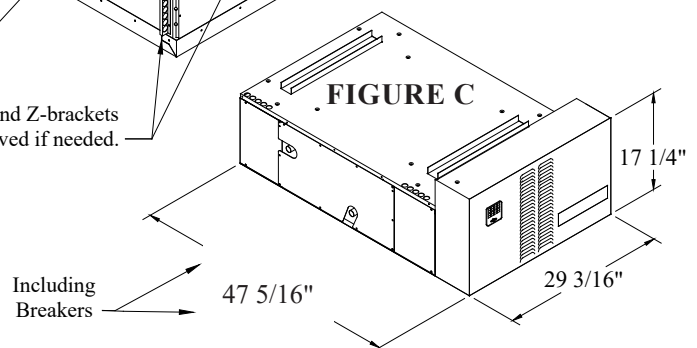
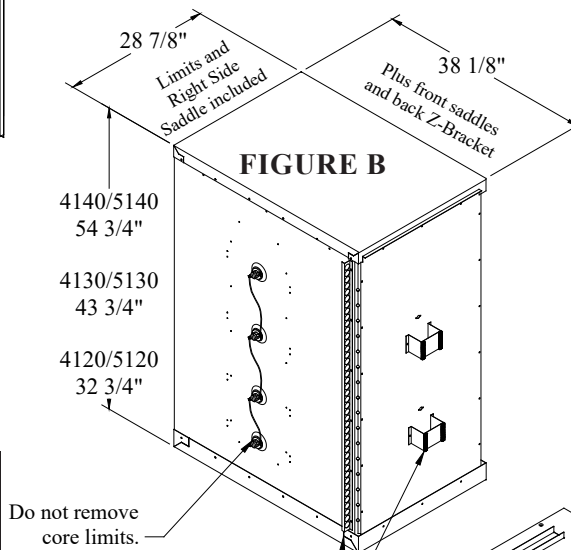
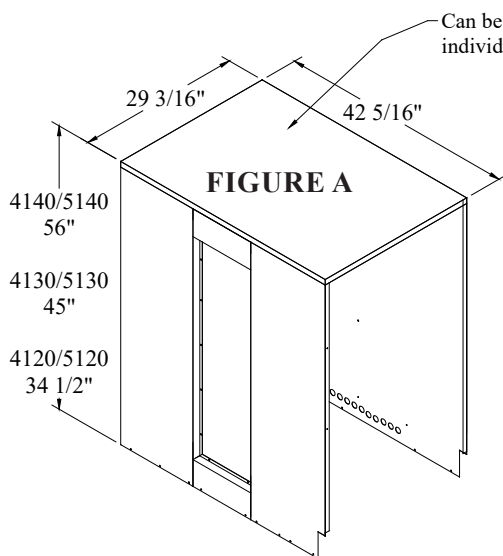

WARNING

HEAVY OBJECT WARNING: Can cause muscle strain or back injury.

- ◆ Use lifting aids to move system into place.
- ◆ Do NOT place object, hands, and/or body parts under the system when lifting.
- ◆ Use care to keep objects, hands, and/or body parts clear of system when lifting.

GLOSSARY

Air Separator ~ Device used to remove air from the water so the air does not get into the closed loop system and cause damage to other components or prevent water circulation.

Air Vent ~ Device used to release air from the system. The air vent is generally mounted on top of the air separator.

Anticipated Peak ~ Used as an alternative method of storing heat in the brick core. Indicated by an "A" on the system display.

Automatic Charge Control ~ Method of brick core charge regulation where a sensor monitors outdoor temperature and automatically adjusts the brick core charge target level accordingly. As the outdoor temperature drops, the target level rises.

Brick Core Charge Level ~ The amount of heat stored in the brick core of the system.

Charge Period ~ Off-peak time in which the system is allowed to store heat in its brick core. Indicated by a "C" on the system display.

Control Panel ~ Contains the buttons to adjust and the display to indicate system functions. Located on the front of the system.

Control Period ~ On-peak time in which the system is not allowed to store heat in its brick core. Indicated by a "P" on the system display.

Edit Mode ~ Process of changing or viewing the values in a microprocessor location. This is accomplished with the use of the mode button, the up arrow button, and the down arrow button.

Expansion Tank ~ When water is heated, expansion takes place. The expansion tank stores the excess water to maintain proper pressure in the system. In most applications, the expansion tank should be installed prior to the pump for optimum performance.

Location (Function) ~ Where the specific operating information of the system is stored. These locations are part of the microprocessor and are accessed through the control panel. Displayed as an "L" on the faceplate when in the edit mode.

Location Value ~ The specific information set and stored in a location on the system's microprocessor which defines system operation. A value for a specific location is accessed through the control panel.

Manual Charge Control ~ Method of brick core charge regulation where the owner must periodically adjust the brick core temperature setting in relation to the outdoor temperature.

Microprocessor ~ Device on the circuit board of the system which stores and processes the information for controlling the operation of the system.

Off-peak ~ The time during the day or night when the power company can supply electricity more economically and may offer a special incentive such as a reduced electric rate or billing credits for the electricity consumed during this time. Typically, electrical usage is not controlled during an off-peak time. (The system will provide heat to satisfy comfort requirements during this time as well as charge or store heat in its brick core.)

On-peak ~ The time during the day or night when the power company experiences a high demand for electricity. To limit demand, certain appliances are controlled to avoid usage by them and/or a premium for the electricity consumed during this time may be charged to discourage electrical usage. (The system is not allowed to charge or store heat in its brick core during on-peak periods.) Indicated by a "P" on the system display.

Outdoor Sensor ~ Device that senses outdoor air temperature and communicates this information to the system for automatic charge control.

Pressure Relief Valve ~ Device that protects the system against the dangers of thermal expansion. If system pressure exceeds normal operating conditions, the relief valve opens and releases excessive pressure from the system.

Room Temperature Set Point ~ The targeted room temperature the system is to maintain. If the thermostat(s) senses a temperature below this point, a heat call is initiated.



Warranty

Registering your purchase is an essential step to ensure warranty coverage. A Warranty Registration card is included with the Owner's Manual. Simply complete, detach the bottom portion, and return the card today. Retain the top portion of the card for your files.

WARRANTY STATEMENT

Steffes Corporation warrants for a period of five (5) years following delivery, limited to seven (7) years from date of manufacture, of any goods provided under this Agreement that the goods purchased hereunder will be of merchantable quality, free from defects in material and workmanship, and that the goods provided will be new and conform to the mechanical and performance specifications referenced in any drawings provided by Steffes Corporation. Customer shall promptly provide notice to Steffes Corporation of any goods which do not comply with such warranty.

THE WARRANTIES SET FORTH HEREIN ARE STEFFES CORPORATION'S SOLE AND EXCLUSIVE WARRANTIES, AND THEY ARE MADE IN LIEU OF ALL OTHER WARRANTIES. THERE ARE NO OTHER WARRANTIES, EXPRESS OR IMPLIED, WHETHER ARISING BY OPERATION OF LAW, STATUTE, USAGE OF TRADE, CUSTOM, COURSE OF DEALING OR PERFORMANCE, THE PARTIES' CONDUCT OR OTHERWISE, FOR ANY PRODUCTS, SERVICES OR OTHER ITEMS SOLD OR FURNISHED BY STEFFES CORPORATION. WITHOUT LIMITING THE GENERALITY OF THE FOREGOING, AND EXCEPT TO THE EXTENT EXPRESSLY STATED HEREIN, STEFFES CORPORATION DISCLAIMS ALL IMPLIED WARRANTIES OF MERCHANTABILITY AND FITNESS FOR A PARTICULAR PURPOSE AND, EXCEPT TO THE EXTENT EXPRESSLY STATED HEREIN, THERE ARE NO WARRANTIES WHICH EXTEND BEYOND THE DESCRIPTION ON THE FACE OF THIS DOCUMENT. STEFFES CORPORATION SHALL NOT BE LIABLE FOR ANY LOSSES, CLAIMS, DAMAGES OR LIABILITY RELATING TO LOST PROFITS OR OTHER CONSEQUENTIAL, INCIDENTAL, EXEMPLARY, PUNITIVE OR INDIRECT DAMAGES IN CONNECTION WITH OR RELATING TO GOODS PROVIDED HEREUNDER.

If the goods fail to meet the warranty requirements set forth herein, as mutually agreed by both Parties, excluding goods which have been subject to misuse, abuse, negligence, accident, improper maintenance or improper operations, Steffes Corporation shall: repair or replace the product or part(s) only which prove to be defective under normal use. The Customer shall be responsible for any labor costs associated with the repair or replacement of the product or part(s), including the cost of returning the defective product or part(s) to Steffes Corporation. This Warranty is void if the product is moved from the premises in which it was originally installed. This Warranty shall not apply to any product or part which has been altered in any respect, or improperly installed, serviced or used, or has been subject to accident, negligence, abuse or misuse.

The Customer assumes all risk and liability whatsoever resulting from the use of this device. In no event shall Steffes be liable for any indirect, special or consequential damages or lost profits.

This Limited Warranty contains the complete and exclusive statement of Steffes' obligations with respect to this device and any parts thereof. The provisions hereof may not be modified in any respect except in writing signed by a duly authorized officer of Steffes.

Thank you for purchasing Steffes ETS heating equipment. We welcome your comments relating to the Comfort Plus and this manual. Enjoy your new purchase!

